

# B125

## **Hardware**

---

### Integration Guide



# **B125**

## **Hardware Integration Guide**

Part Number 1008514-01

Rev A

**©Copyright Topcon Positioning Systems, Inc.**

April, 2017

All contents in this manual are copyrighted by Topcon Positioning Systems, Inc. All rights reserved.

# Table of Contents

.....

<b>Preface</b> .....	<b>v</b>
Terms and Conditions .....	v
Use .....	v
Copyrights .....	v
Trademarks .....	v
Disclaimer of Warranty .....	v
License Agreement .....	vi
Confidentiality .....	vi
Website; Other Statements .....	vi
Safety .....	vi
Miscellaneous .....	vi
About This Guide .....	vi
Manual Conventions .....	vii
Intended Audience and Qualification .....	vii
Hardware and Firmware Versions .....	vii
Additional Documentation .....	vii
Revision History .....	viii
Getting Technical Assistance .....	viii
Check This First! .....	viii
Contacting Technical Support .....	viii
E-mail .....	viii
Website .....	ix
<b>Getting Acquainted</b> .....	<b>1</b>
Before You Start .....	1
Preventing Electrostatic Damage .....	1
Checking the Package Contents .....	2
Handling of the B125 Board .....	2
Installing TRU Software .....	2
Overview .....	3
Features .....	3
Board Layout and Main Hardware Components .....	4
Block Diagram .....	5
Minimum Requirements to Run the B125 .....	5

Hardware Components and Interfaces . . . . .	6
Connector Types . . . . .	6
Interface Connector . . . . .	6
GNSS Antenna Connectors . . . . .	6
Power System . . . . .	7
Primary Power Rail . . . . .	7
Backup Power Rail . . . . .	7
USB Host and Antenna J101 Power Rail . . . . .	8
USB Device Power Rail . . . . .	8
Power Controls . . . . .	8
PBTN . . . . .	8
PORESET . . . . .	9
Board Behavior during Power-up and Power-down . . . . .	9
Sleep Mode . . . . .	9
STAT LED . . . . .	9
REC LED . . . . .	10
GNSS Antenna . . . . .	10
UART . . . . .	11
USB . . . . .	12
CAN . . . . .	13
Ethernet . . . . .	14
1PPS . . . . .	14
Event Marker . . . . .	15
SD/SDIO . . . . .	15
General Purpose I/O . . . . .	16
Function Control . . . . .	16
Firmware Features . . . . .	17
Real-Time Kinematic Engine . . . . .	17
Network-based RTK Techniques . . . . .	17
Precise Point Positioning Engine . . . . .	18
Enhanced Positioning Engine (DION) . . . . .	18
Satellite Based Augmentation System (SBAS) . . . . .	18
Quartz Lock Loop . . . . .	19
Network Services and Protocols . . . . .	19
TCP Client/Server . . . . .	19
FTP Client/Server . . . . .	19
DNS Server . . . . .	20
DHCP Client . . . . .	20
Ntrip Protocol . . . . .	20
File System . . . . .	20

Option Authorization File (OAF) . . . . .	21
Design Guidelines . . . . .	22
Board Orientation and Mounting . . . . .	22
Pin Numbering and Connectivity to Target Hardware . . . . .	22
Cooling/Heating Requirements . . . . .	22
General Guidelines . . . . .	23
Power . . . . .	23
USB . . . . .	23
Ethernet . . . . .	23
SD/SDIO . . . . .	24
Approved SD Cards . . . . .	24
Product Compliance . . . . .	24
<b>Using Evaluation Board . . . . .</b>	<b>25</b>
Overview . . . . .	25
Connector and Component Locations . . . . .	26
Quick-Start to Run the B125 Installed on the Evaluation Board . . . . .	27
B125 Evaluation Board Components and Connectors . . . . .	30
GNSS Antenna Inputs . . . . .	30
Power Connectors . . . . .	30
Keys . . . . .	31
LEDs . . . . .	31
Jumpers . . . . .	32
Interface Connector . . . . .	33
Test Pads and Points . . . . .	36
UART Interfaces . . . . .	37
USB . . . . .	38
Ethernet . . . . .	38
CAN . . . . .	39
SD Card . . . . .	39
Backup battery . . . . .	40
1PPS . . . . .	40
Event Marker . . . . .	40
<b>Specifications . . . . .</b>	<b>41</b>
Board Specifications . . . . .	41
Connector Specifications . . . . .	45
Interface Connector . . . . .	45
GNSS Antenna Connectors . . . . .	48

Mechanical and Schematic Drawings. . . . .	49
B125 Dimensions . . . . .	49
B125EVB Schematics . . . . .	50

# Preface



Thank you for purchasing this Topcon product. The materials available in this Manual (the "Manual") have been prepared by Topcon Positioning Systems, Inc. ("TPS") for owners of Topcon products, and are designed to assist owners with the use of the receiver and its use is subject to these terms and conditions (the "Terms and Conditions").



Please read the terms and conditions carefully.

## Terms and Conditions

### Use

This product is designed to be used by a professional. The user should have a good knowledge of the safe use of the product and implement the types of safety procedures recommended by the local government protection agency for both private use and commercial job sites.

### Copyrights

All information contained in this Manual is the intellectual property of, and copyrighted material of TPS. All rights are reserved. Do not use, access, copy, store, display, create derivative works of, sell, modify, publish, distribute, or allow any third party access to, any graphics, content, information or data in this Manual without TPS' express written consent and may only use such information for the care and operation of the receiver. The information and data in this Manual are a valuable asset of TPS and are developed by the expenditure of considerable work, time and money, and are the result of original selection, coordination and arrangement by TPS.

### Trademarks

B125™, TRU™, Magnet™, Topcon® and Topcon Positioning Systems™ are trademarks or registered trademarks of TPS. Windows® is a registered trademark of Microsoft Corporation. The Bluetooth® word mark and logos are owned by Bluetooth SIG, Inc. and any use of such marks by Topcon Positioning Systems, Inc. is used under license. Other product and company names mentioned herein may be trademarks of their respective owners.

### Disclaimer of Warranty

EXCEPT FOR ANY WARRANTIES IN AN APPENDIX OR A WARRANTY CARD ACCOMPANYING THE PRODUCT, THIS MANUAL AND THE RECEIVER ARE PROVIDED "AS-IS." THERE ARE NO OTHER WARRANTIES. TPS DISCLAIMS ANY IMPLIED WARRANTY OF MERCHANTABILITY OR FITNESS FOR ANY PARTICULAR USE OR PURPOSE. TPS AND ITS DISTRIBUTORS SHALL NOT BE LIABLE FOR TECHNICAL OR EDITORIAL ERRORS OR OMISSIONS CONTAINED HEREIN; NOR FOR INCIDENTAL OR CONSEQUENTIAL DAMAGES RESULTING FROM THE FURNISHING, PERFORMANCE OR USE OF THIS MATERIAL OR THE RECEIVER. SUCH DISCLAIMED DAMAGES INCLUDE BUT ARE NOT LIMITED TO LOSS OF TIME, LOSS OR DESTRUCTION OF DATA, LOSS OF PROFIT, SAVINGS OR REVENUE, OR LOSS OF THE PRODUCT'S USE. IN ADDITION TPS IS NOT RESPONSIBLE OR LIABLE FOR DAMAGES OR COSTS INCURRED IN CONNECTION WITH OBTAINING SUBSTITUTE PRODUCTS OR SOFTWARE, CLAIMS BY OTHERS, INCONVENIENCE, OR ANY OTHER COSTS. IN ANY EVENT, TPS SHALL HAVE NO LIABILITY FOR DAMAGES OR OTHERWISE TO YOU OR ANY OTHER PERSON OR ENTITY IN EXCESS OF THE PURCHASE PRICE FOR THE RECEIVER.

## License Agreement

Use of any computer programs or software supplied by TPS or downloaded from a TPS website (the "Software") in connection with the receiver constitutes acceptance of these Terms and Conditions in this Manual and an agreement to abide by these Terms and Conditions. The user is granted a personal, non-exclusive, non-transferable license to use such Software under the terms stated herein and in any case only with a single receiver or single computer. You may not assign or transfer the Software or this license without the express written consent of TPS. This license is effective until terminated. You may terminate the license at any time by destroying the Software and Manual. TPS may terminate the license if you fail to comply with any of the Terms or Conditions. You agree to destroy the Software and manual upon termination of the use of the receiver. All ownership, copyright and other intellectual property rights in and to the Software belong to TPS. If these license terms are not acceptable, return any unused software and manual.

## Confidentiality

This Manual, its contents and the Software (collectively, the "Confidential Information") are the confidential and proprietary information of TPS. You agree to treat TPS' Confidential Information with a degree of care no less stringent than the degree of care you would use in safeguarding your own most valuable trade secrets. Nothing in this paragraph shall restrict you from disclosing Confidential Information to your employees as may be necessary or appropriate to operate or care for the receiver. Such employees must also keep the Confidentiality Information confidential. In the event you become legally compelled to disclose any of the Confidential Information, you shall give TPS immediate notice so that it may seek a protective order or other appropriate remedy.

## Website; Other Statements

No statement contained at the TPS website (or any other website) or in any other advertisements or TPS literature or made by an employee or independent contractor of TPS modifies these Terms and Conditions (including the Software license, warranty and limitation of liability).

## Safety

Improper use of the receiver can lead to injury to persons or property and/or malfunction of the product. The receiver should only be repaired by authorized TPS warranty service centers. Users should review and heed the safety warnings in an Appendix.

## Miscellaneous

The above Terms and Conditions may be amended, modified, superseded, or canceled, at any time by TPS. The above Terms and Conditions will be governed by, and construed in accordance with, the laws of the State of California, without reference to conflict of laws.

## About This Guide

Welcome to the B125 Hardware Integrator Guide!

This manual is designed to be a comprehensive hardware guide to the B125 GNSS board. The material in this manual describes the features, hardware components, installation, operation, and specifications of the B125 board.

In addition, this manual describes the features and functionality of the B125 Development Kit, which includes the evaluation board, software, and all necessary cables.



## Manual Conventions

This manual uses the following conventions:

Convention	Description	Example
<b>Bold</b>	Menu, or drop-down menu selection	<b>File</b> ▶ <b>Exit</b> (Click the <b>File</b> menu and click <b>Exit</b> )
	Name of a dialog box or screen	From the <b>Connection</b> screen...
	Button or key commands	Click <b>Finish</b> .
Mono	User supplied text or variable	Type <code>guest</code> , and click <b>Enter</b> .
<i>Italic</i>	Reference to another manual or help document	Refer to the <i>Topcon Reference Manual</i> .



Further information to note about system configuration, maintenance, or setup.



Supplementary information that can have an adverse affect on system operation, system performance, data integrity, measurements, or personal safety.



Notification that an action has the potential to result in system damage, loss of data, loss of warranty, or personal injury.

## Intended Audience and Qualification

This manual is intended for system engineers, system designers, and programmers who are integrating the B125 board to their products to achieve GNSS positioning capabilities.

It is highly recommended that installation, commissioning, use, and maintenance of the B125 board are preformed by personnel trained in electronics.

## Hardware and Firmware Versions

The information in this manual corresponds to the following hardware and firmware versions:

- B125 board hardware revision 4.6.
- B125EVB board hardware revision 2.2
- GNSS firmware version 5.1p1

## Additional Documentation

The following documentation can be useful while working with the B125 board:

- *Maintenance Guide* (1020443-01) – explains how to maintain the B125 for various tasks using GRIL commands.
- *GRIL Reference Manual* (27-040004-01) – contains an exhaustive description of the GNSS Receiver Interface Language (GRIL) used to communicate and control a TPS receiver, including the B125.
- *TRU Help* – explains how to install, set up, and use the TRU software on desktop computers and hand-held controllers.

## Revision History

Revision	Date (yyyy-mm-dd)	Changes
A	2017-Mar-30	Initial release of the B125 Hardware Integration Guide.

## Getting Technical Assistance

Should you have any questions about the B125 or experience any problems with this board, contact Topcon OEM Solutions technical support for immediate and comprehensive assistance.



Do not attempt to repair equipment yourself. Doing so will void your warranty and may damage the hardware.

## Check This First!

Before contacting Topcon OEM Solutions technical support, check the following:

- Check all external board connections carefully to ensure correct and secure connections. Double check for worn or defective cables.
- Check all power sources to ensure their correct operation.
- Check that the most current software is downloaded onto the computer and that the most current firmware is loaded into the board. Check the Topcon [TotalCare](#) support website for the latest updates.
- Check that the desired OAF options are enabled in the board.  
Then, try the following:
  - Reset the board using TRU (**Tools ▶ Reset Receiver**) or a GRIL command (`set,/par/reset,yes`).
  - Restore default settings using TRU (**Tools ▶ Reset Parameters**) or a GRIL command (`init,/setup/`).
  - Clear the NVRAM using TRU (**Tools ▶ Factory Reset**) or a GRIL command (`init,/dev/nvm/a`).

If the problem persists, see the following section for contact information.

## Contacting Technical Support

If the troubleshooting hints and tips in this guide fail to remedy the problem, contact Topcon OEM Solutions technical support.

### E-mail

To contact Topcon OEM Solutions technical support via e-mail, use the [OEMsupport@topcon.com](mailto: OEMsupport@topcon.com) electronic mail address.

When e-mailing TPS technical support, provide the following information for better, faster service:

1. The board model and configuration settings. This information can be retrieved using TRU ▶ **Information ▶ Save to File**. Save the receiver's output to a text file. Attach this file to the email and submit it to Topcon OEM Solutions technical support.
2. The system/hardware specifications for the computer running TRU or a custom application; such as, operating system and version, memory and storage capacity, processor speed, etc.
3. The symptoms and/or error codes/messages that precede and follow the problem.
4. The activities being tried when the problem occurs. If possible, include the exact steps being taken up to when the error message or other problem occurs.
5. How regularly the problem occurs.

Generally, an OEM Solutions technical support representative will reply within 8 business hours or less, depending on the severity of the problem.

**Website**

The Topcon Positioning Systems website provides current information about Topcon's line of OEM products. For more information about OEM products, visit [www.topconpositioning.com/oem](http://www.topconpositioning.com/oem).

# Getting Acquainted

The B125 board is the most advanced and flexible multi-frequency GNSS receiver designed for OEM applications. Building on the proven platform of the B110 and the success of the Vanguard™ chip, the B125 offers greatly expanded tracking and communication capabilities while maintaining the B110 heritage of compact footprint and low power consumption.

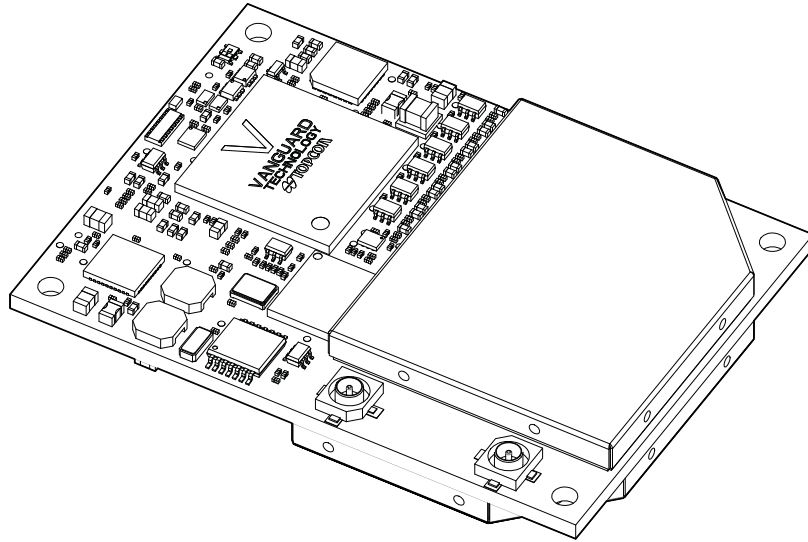

Figure 1: B125 Board

## Before You Start

Before using the B125 board, it is recommended to read the following sections. They were especially designed to help you correctly integrate, setup, and operate the board.

## Preventing Electrostatic Damage

The B125 board contains electronic components that are sensitive to electrostatic discharge (ESD). It can occur suddenly and without any visible effect at any point throughout unpacking, installing, test, or operational processes. If not properly controlled, a discharge of static electricity can badly affect or even damage the board. To protect your board from the effects of static damage, implement the following methods of ESD control:

- All manipulations with the board must be performed within an ESD-protected area. Such an area must meet certain environment conditions and contain materials and equipment designed to minimize the damage from ESD.
  - The relative humidity must be maintained above a minimum of 30% in the ESD-protected area.
  - The board must be kept and transferred in an ESD-protective container, for example, in a static-safe bag.
- All personnel and equipment within the ESD-protected area must be properly grounded to ensure they are at the same electrical potential.
  - A wrist strap must be worn snugly against the user's bare skin and be connected to the common point ground. The wrist strap must also have a current limiting resistor with a minimum of one megohm  $\pm 20\%$  resistance in the ground cord.
  - When standing or walking around in your working area, it is highly recommended to use ESD protective floors in conjunction with ESD control footwear or foot straps. All these items must also be properly grounded to the common point ground.

For additional information about ESD control procedures visit the ESD Association website at [www.esda.org](http://www.esda.org).

## Checking the Package Contents

When you unpack the B125 package, verify that you received all of the items listed in this section. Inspect the B125 board and other items included to ensure that they have not been damaged during shipment. Verify that all components are mounted on the board and appear intact.

If any of the items are missing or damaged, contact your Topcon dealer or Topcon technical support. See [“Contacting Technical Support” on page viii](#) for contact information.

Retain the factory packaging for storage and/or in case there is a need to return the board.

The development kit (p/n 1008510-01) includes the following items:

- B125EVB evaluation board with assembled standoffs and five jumpers (p/n 1006226-01)
- SD card (p/n 1017044-01)
- two RF cables (p/n 14-004159-01LF)
- standard null-modem cable (p/n 14-008086-01)
- USB cable (p/n 14-008081-01)
- Ethernet cable (p/n 14-850407-01)
- power supply with cable for North America (p/n 60815)

The B125 board in the development kit is also available as a standalone module in single unit and volume quantities. A standalone package does not include the B125EVB board, cables, jumpers, and power supply.

## Handling of the B125 Board

Handle the board by the edges only. Avoid touching the connector pins or any other electronic components of the board.

## Installing TRU Software

TRU is a Windows® software application designed for configuring GNSS receivers, including GNSS OEM boards, modem boards, and Bluetooth modules.

Computer requirements for TRU are: Microsoft® Windows XP or newer and an RS-232C or USB port or computer with Bluetooth wireless technology.

This software is available on the Topcon [TotalCare](#) support website to registered users.

After downloading the program from the website, extract the program's files into a folder on your hard drive.

To install TRU on a PC:

1. Navigate to the TRU folder, and double-click **TRU.zip**.
2. Extract **TRU.exe** to a folder.
3. Double-click **TRU.exe** to run the installer, and then follow the on-screen instructions.

To uninstall TRU, use **Add or Remove Programs** in Microsoft® Windows.

# Overview

## Features

- **Vanguard RF™** and **Vanguard™** chips – A potent blend of the latest Topcon developments in digital and analog processing that delivers 224 universal channels and up to 100 Hz measurement and position-velocity-time update rates.
- **Future-proof signal tracking** – Receiving and processing GPS, Glonass, Galileo, BeiDou, and QZSS signals.
- **Multi-frequency RTK engine** – Powerful and robust RTK engine designed for single-base and network operations.
- **DGNSS** – Ground-based and satellite-based submeter positioning using L1 code measurements.
- **TopNET Global -D** – L-Band PPP correction service.
- **Doppler filter** – Configurable bandwidth to minimize the noise and dynamic errors in the velocity output.
- **Velocity filter** – Second stage of velocity filtering for even smoother velocity output.
- **DION** – Enhanced absolute positioning engine that allows you to use a single B125 to compute smoothed and consistent position solutions.
- **HD2** – 2-D attitude determination using a pair of B125 boards.
- **1PPS** – Highly-reliable and very accurate reference timing source for external devices.
- **Event input** – Accurately record the time an external event occurs in the specified reference time.
- **Multipath mitigation** – Considerable mitigation of C/A code and carrier phase multipath errors using a proprietary signal processing algorithm.
- **Quartz-Locked Loop (QLL)** – Permanent monitoring, detection, and isolation of the vibration-induced frequency deviations for improved survivability and performance of a B125 in dynamic applications.
- **Adjustable phase-locked and delay-locked loops** – Optimize the tracking performance by adjusting the parameters of the PLLs and DLLs.
- **Two RS-232C interfaces and one LVTTTL interface** – Full-duplex, independent, and fully configurable RS-232C and LVTTTL serial ports with data rates of up to 460.8 Kbit/s.
- **High-speed USB 2.0 interface** – USB host<sup>1</sup> to connect a removable, high-capacity storage medium for recording raw data files and uploading firmware; USB device for board configuration and control from a PC.
- **SD/SDIO interface** – Record raw data files to a compact, removable, and solid storage medium.
- **10/100 Mbit Ethernet interface** – Control and monitor your board remotely over a TCP/IP network connectivity.
- **Network capabilities** – A range of network protocols and services including TCP Client/Server, FTP Client/Server, DNS, DHCP Client, Ntrip Client/Server.
- **CAN interface without transceiver** – CAN bus connection that conforms to the CAN specification 2.0 A/B and provides output of two NMEA 2000 messages.
- **On-board LED for tracking and operation awareness** – The board provides a STAT LED to view satellites and position status.
- **Five dedicated GPIOs for external LEDs** – Control the behavior of STAT and REC LEDs with the five dedicated GPIOs.
- **Command interface** – A rich set of commands, text and binary messages to control every part of your B125 board.
- **Dedicated pin for backup power source** – Implement a backup power source to ensure your settings and other valuable data are instantly saved to the NVRAM where they are securely retained for future usage.
- **File system** – A part of the firmware is a FAT32 file system that allows you to create, store, retrieve, and delete the raw data files day by day with guaranteed file system integrity.
- **Automatic File Rotation Mode** – Automatically close and open tps files at scheduled, evenly spaced times.

---

1. A USB host functionality is currently disabled. It will be enabled through a future firmware update.

- **Advanced Input Mode** – Enable any port to handle multiple formats of data simultaneously. Whether they are GRIL commands or RTCM messages, AIM will recognize them and forward each to the proper decoder, all through the same port.
- **Job Programming** – Configure time-based scheduling to run single or multiple GRIL commands for automatic processing 24 hours a day, 7 days a week.
- **Output Duplication** – Duplicate the same output data to ports without making the board to generate these data for each port.
- **Pass-through Mode** – Any board port becomes a transparent channel, which passes through all input data to another port of your choice with or without interpretation of input data. Furthermore, a bidirectional transparent channel which passes through all input data from one port to another and vice versa can easily be established.
- **Universal Break Sequence** – Never have your board locked up because of unresponsive ports.
- **Sleep mode** – Minimize power consumption by putting the board in a dormant state and awake it up at a specified GPS time.

## Board Layout and Main Hardware Components

Figure 2 shows the B125 board layout and identifies major hardware components.

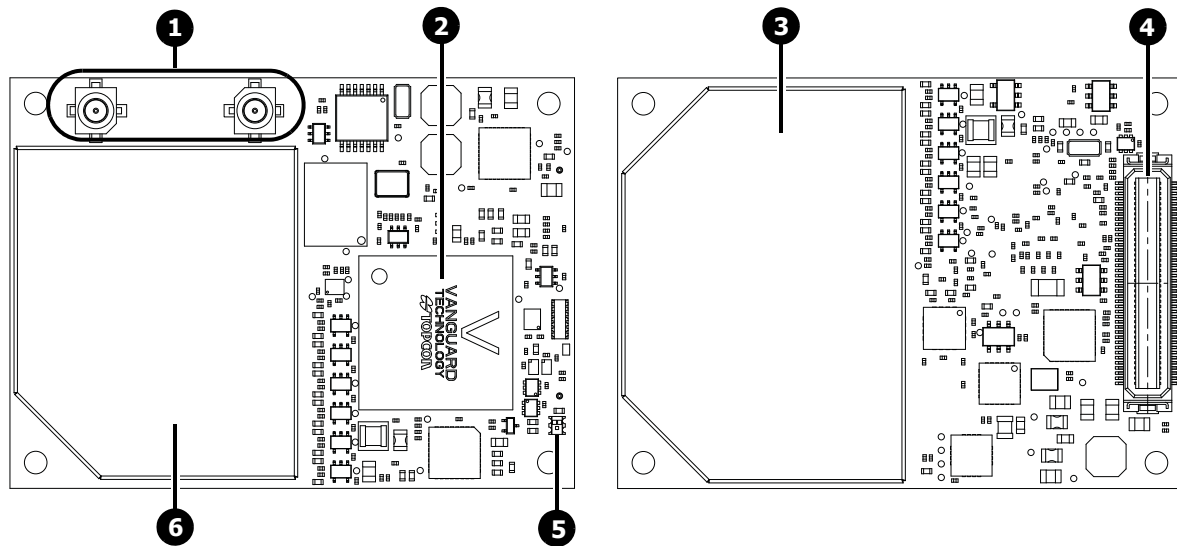

**Figure 2: B125 Layout**

Table 1 describes component functions and features.

**Table 1. B125 Components**

No.	Component (Board Reference)	Description
1	Antenna connectors (J100, J101)	The GNSS antenna connectors of Hirose H.FL Straight Through Hole are used for connecting GNSS antennas. For antenna requirements, see <a href="#">"GNSS Antenna" on page 10</a> . For connector details and pin descriptions, see <a href="#">"GNSS Antenna Connectors" on page 48</a> .
2	Vanguard chip (U401)	The Vanguard chip manages satellite measurement data from the RF section, controls system memory, navigation processing and communication interfaces.
3, 6	RF section with Vanguard RF chip	The radio frequency section receives, amplifies, and filters the incoming satellite signals.
4	Interface connector (J500)	The interface connector is used for data transfer, board management, and power distribution. For connector details and pin descriptions, see <a href="#">"Hardware Components and Interfaces" on page 6</a> and <a href="#">"Interface Connector" on page 45</a> .
5	STAT LED (D403)	The STAT LED displays the status of the tracked satellites. For blinking patterns and their meaning, see <a href="#">"STAT LED" on page 9</a> .

# Block Diagram

A simplified hardware architecture of the B125 is shown in Figure 3.

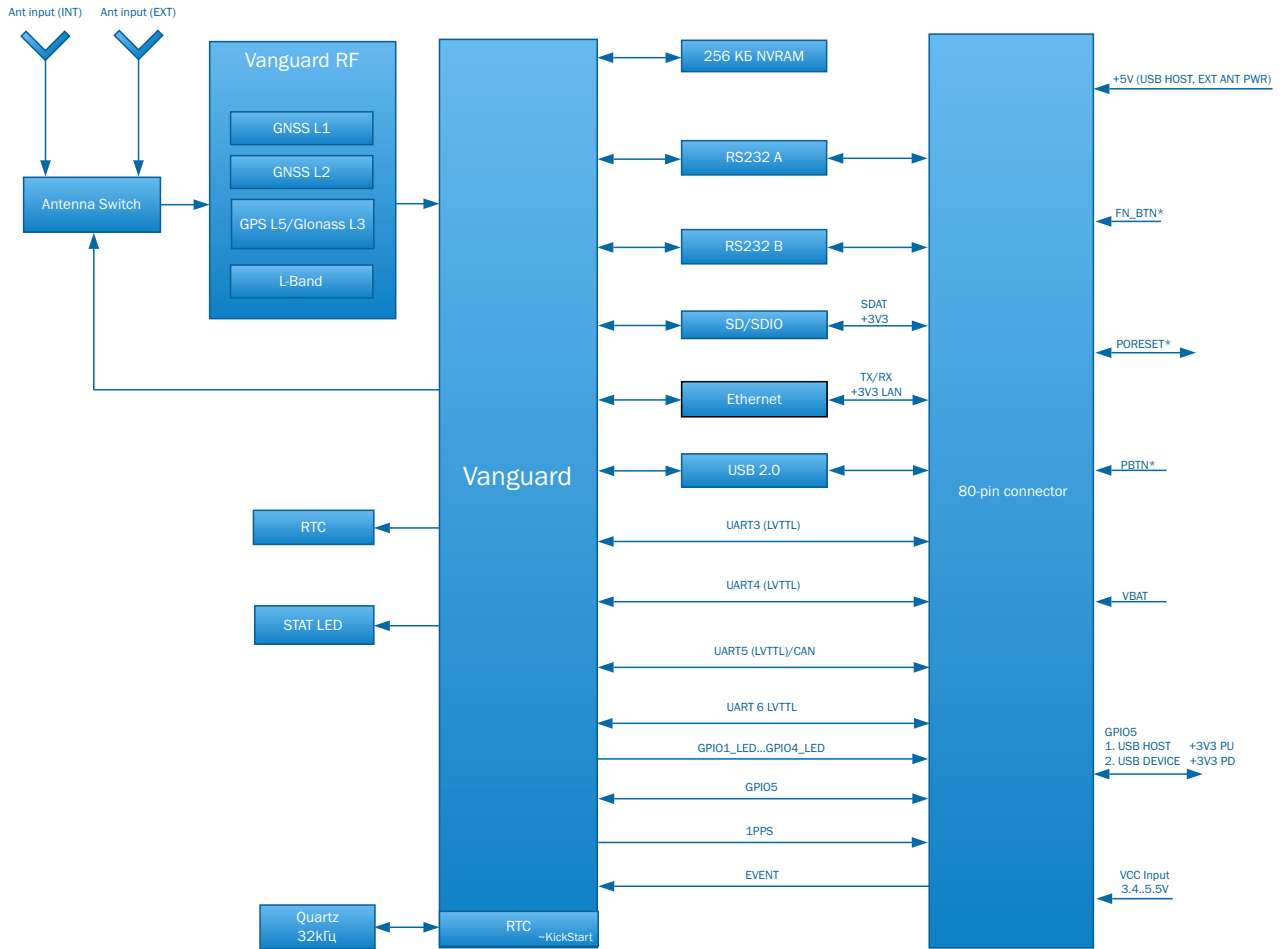

**Figure 3: B125 Block Diagram**

## Minimum Requirements to Run the B125

For a basic operation, the B125 requires a power supply with a constant voltage between +3.4 Vdc and +5.5 Vdc at a loading current of 2 A, corresponding GND connections, a single UART interface, and an active GNSS antenna connection.

The pins for the power supply, GND, and UART are located at the J500 connector as shown in Table 2. Pin no.1 is top-right and pin no.2 is bottom-right when you look at the connector with a metallic RF shield below

**Table 2. Minimum Pin Connection**

Signal Name	Pin No.	Pin Locations
PWR_IN	2, 4, 6	
GND	3, 5	
RS_RTSA, RS_CTSA	35, 36	
RS_TXDA, RS_RXDA	37, 38	

The GNSS antenna connection is at the J100.



# Hardware Components and Interfaces

## Connector Types

The B125 uses a single interface connector and two GNSS antenna connectors.

### Interface Connector

The interface connector J500 is used for data transfer, board management, and power distribution.

**Table 3. Interface Connector**

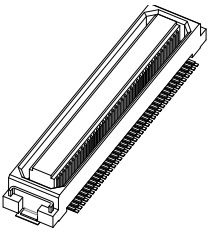
Manufacturer	Hirose ( <a href="http://www.hirose-connectors.com">http://www.hirose-connectors.com</a> )	
Manufacturer part number	DF17(3.0)-80DS-0.5V(57)	
Connector type	Female	
Number of rows	2	
Number of contacts per row	40	
Total number of contacts	80	

**Table 4. Mating Interface Connector**

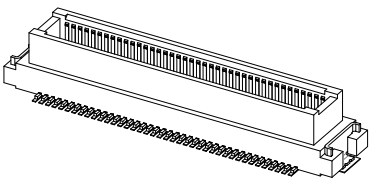
Manufacturer	Hirose ( <a href="http://www.hirose-connectors.com">http://www.hirose-connectors.com</a> )	
Manufacturer part number	DF17(2.0)-80DP-0.5V(57)	
Connector type	Male	
Number of rows	2	
Number of contacts per row	40	
Total number of contacts	80	

### GNSS Antenna Connectors

The B125 uses two GNSS antenna J100 and J101 connectors for connecting GNSS antennas.

**Table 5. GNSS Antenna Connectors**

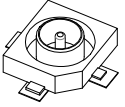
Manufacturer	Hirose ( <a href="http://www.hirose-connectors.com">http://www.hirose-connectors.com</a> )	
Manufacturer part number	H.FL-R-SMT(10)	
Connector type	Male	

**Table 6. Mating GNSS Antenna Connectors**

Manufacturer	Any	
Connector type	H.FL Female Jack	

## Power System

The B125 operates various on-board components via four power rails:

- Primary power rail
- Backup power rail
- USB host and antenna J101 power rail
- USB device power rail

### Primary Power Rail

The B125 uses the primary power rail to power Vanguard RF and Vanguard chips, system memory, communication interfaces (except USB host), antenna at J100, and other electronic components. The primary power rail requires an input voltage range from +3.4 Vdc to +5.5 Vdc at a loading current of 2 A and less than a 150 mV ripple voltage.



A 2-Amps power supply is required to handle a peak inrush current generated upon the board startup.

Connect all PWR\_IN pins on the connector J500 to an external power supply and the corresponding GND pins to a solid ground plane.

- PWR\_IN pins: 2, 4, 6
- Corresponding GND pins: 3, 5

After connecting the external power supply to the PWR\_IN pins, an integrated power management IC (U413) generates three different, continuous voltages 1.2 V, 1.8 V, and 3.3 V required by the various on-board components.



The on-board power management IC filters out input noise and ripple, allowing you to use a loosely regulated power supply provided the input voltage falls within an acceptable range.



Applying inappropriate voltages to power pins can damage the B125 board or make its operations unstable, specifically:

- Exceeding the maximum input voltage can damage the B125 board or the connected equipment.
- Dropping below the minimum input voltage can cause improper performance of the B125 board or damage to the B125 board.

### Further Reading:

- Pin descriptions in ["Interface Connector" on page 45](#).
- Design guidelines about power system integration in ["Power" on page 23](#).

### Backup Power Rail

The B125 board uses the backup power rail to supply the power to an internal real-time clock (RTC) and the Non-Volatile Random Access Memory (NVRAM) when an external power supply has been discharged or removed.

The RTC stores the time and date information while the NVRAM keeps data required for satellite tracking and the current settings (such as elevation masks, serial port baud rate, etc.).

An on-board supervisory circuit monitors power supply conditions and automatically switches between the primary power rail and the backup power rail when needed.



A backup power source is not installed on the B125 board.

To implement backup functionality, you need to connect a backup power source to VBAT pin (no. 22) of the interface connector (J500). The backup power source must supply the voltage in the range of 1.8 V to 3.6 V. The recommended backup power source is the Tadiran Batteries' lithium battery TL-2450. This battery is rated at about 8 years of operation at typical consumption and ambient temperature of 25° C.

The RTC and NVRAM draw approximately 3  $\mu$ A at ambient temperature of 25° C when the voltage from an external power supply is not applied. As long as the B125 is powered through the primary power rail, the RTC and NVRAM are sourced from this rail and draw no current from the backup power rail.

If you do not need a backup power for the RTC and NVRAM, leave the VBAT pin unconnected.



Without a backup power supply connected, the B125 will reset all settings to default values and a cold start condition will occur each time the B125 is power cycled.

#### Further Reading:

- Pin descriptions in ["Interface Connector" on page 45](#).
- Design guidelines about power system integration in ["Power" on page 23](#).
- An example of how the backup battery connects to the evaluation board in ["Backup battery" on page 40](#).

### USB Host and Antenna J101 Power Rail

If you use the USB interface in host<sup>1</sup> mode or a connected GNSS antenna at J101, you need to provide the 5 V supply voltage to the +5V pin (no. 1) of the interface connector J500.

If you do not use a USB host or J101 antenna, leave the +5 pin unconnected.

#### Further Reading:

- Pin descriptions in ["Interface Connector" on page 45](#).
- Design guidelines about power system integration in ["Power" on page 23](#).

### USB Device Power Rail

If you use the USB interface in device mode, you need to provide a 5V input on the USB\_PWR pin (no. 48) of the interface connector J500 to power the USB device interface of the B125.

If you do not use a USB device, leave the USB\_PWR pin unconnected.

#### Further Reading:

- Pin descriptions in ["Interface Connector" on page 45](#).
- Design guidelines about power system integration in ["Power" on page 23](#).

## Power Controls

### PBTN

The PBTN\* signal (pin no. 20 on J500) is an active-low input that powers up or down the B125 depending on how long the signal is LOW (GND).

**Table 7. PBTN Functions**

Function	Duration of LOW state	Description
Power-up	1-3 seconds	To power up the board, pull the signal LOW (GND) for more than 1 second and less than 3 seconds.
Power-down	3-10 seconds	To power down the board, pull the signal LOW (GND) for more than 3 seconds and less than 10 seconds.

The PBTN\* signal has an on-board pull-up resistor of 100 KOhm to 3.3 V and can be left unconnected if unused.

1. A USB host functionality is currently disabled. It will be enabled through a future firmware update.

**Further Reading:**

- Pin descriptions in ["Interface Connector" on page 45](#).
- Design guidelines about power system integration in ["Power" on page 23](#).

**PORESET**

The PORESET\* signal (pin no. 45 on J500) is an active-low input that causes the B125 board to enter the reset state.

To reset the board, pull the signal LOW (GND) for at least 0.1 second.

The PORESET\* signal has an on-board pull-up resistor of 10 KOhm to 3.3V and can be left unconnected if unused.

**Further Reading:**

- Pin descriptions in ["Interface Connector" on page 45](#).
- Design guidelines about power system integration in ["Power" on page 23](#).

**Board Behavior during Power-up and Power-down**

After you power up the board, the GNSS part of firmware starts up nearly instantaneously and is ready for tracking satellites and positioning within a few seconds. The peripheral part of firmware needs a bit longer to start up and initialize various services and communication interfaces. It takes up to 2 minutes to achieve a fully working state for the peripheral firmware.

When you power down the board, the STAT LED starts blinking yellow until the board completes the power-off sequence. It takes from 30 seconds up to 120 seconds to complete the power-off sequence. Do not disconnect the power supply until the STAT LED is off.

You can monitor power-up and power-down progress by periodically sending the command `%%print, /par/dev/core:on`. The command shows operating conditions for the GNSS and peripheral parts of firmware.

**Further Reading:**

Usage guidelines about the `/par/dev/core` parameter in the [GRIL Reference Manual](#).

**Sleep Mode**

You can put the B125 board into a dormant state to minimize power consumption without turning off the board completely. The board enters into sleep mode immediately after you send the corresponding GRIL command and stays in this mode until you turn on the board manually or the board detects any activity on serial ports A or B. You can also awaken the board from sleep mode at a specified GPS time using the wake-up option.

**Further Reading:**

How to enter and exit sleep mode in the [GRIL Reference Manual](#).

**STAT LED**

The B125 board provides one STAT LED (D403) that displays the status of the tracked satellites. Table 8 lists the colors of the STAT LED blinks and their functions when the B125 is powered on.

**Table 8. STAT LED Color**

STAT LED Color	Description
Red	No satellites being tracked.
Green	The board is tracking GPS satellites; one blink per tracked GPS satellite.
Yellow	The board is tracking GLONASS satellites; one blink per tracked GLONASS satellite.
Cyan	The board is tracking GALILEO satellites; one blink per tracked GALILEO satellite.
Purple/magenta	The board is tracking BeiDou satellites; one blink per tracked BeiDou satellite.
Blue	The board is tracking QZSS LEX satellites; one blink per tracked QZSS LEX satellite.
White	The board is tracking L-Band satellite; one blink per tracked L-Band satellite.

When satellites are tracked, the sequence of blinks is as follows:

- One green blink for each tracked GPS satellite.
- One yellow blink for each tracked GLONASS satellite.
- One cyan blink for each tracked GALILEO satellite.
- One purple blink for each tracked BeiDou satellite.
- One blue blink for each tracked QZSS LEX satellite.
- One white blink for each tracked L-Band satellite.
- One red blink if the board is not tracking satellites or cannot compute a position. Otherwise, the board produces a pause.

The STAT LED is available through GPIO1\_LED...GPIO3\_LED signals (pin nos. 33, 39, 40) of the J500 connector.

#### Further Reading:

[“General Purpose I/O” on page 16.](#)

## REC LED

The REC LED displays the data recording status of the SD card and USB drive and other memory related information, such as the amount of remaining space on the storage medium, deletion of files, memory initialization process, and fault condition as shown in Table 9.

The REC LED is available through GPIO4\_LED (no. 41) and GPIO5 (no. 43) pins of the J500 connector.

When data recording is in progress, each blink indicates that data is being written to the storage medium. A maximum rate of the REC LED blinks is 1 Hz.

**Table 9. REC LED Color**

REC LED Color	Description
Green	Remaining memory space is 50% or more.
Yellow	Remaining memory space is between 50% and 10%.
Red	Remaining memory space is 10% or less.
Alternating red and green	The files are being deleted.
Alternating red and yellow	The storage medium is being initialized.
Dark	Fault condition with the memory/file system: no more memory, no storage medium, no OAF for file logging, faulty memory or other hardware problem.

#### Further Reading:

[“General Purpose I/O” on page 16.](#)

## GNSS Antenna

The B125 board is primarily designed for use with Topcon active antennas. However, flexibility exists to accommodate for custom active antennas.



Topcon cannot guarantee the correct performance with other brands of GNSS antenna. Do not use passive GNSS antennas with the B125.

Before connecting an active GNSS antenna, consider the following operating conditions:

- For powering an LNA of the GNSS antenna connected to J100, the board supplies a voltage in the range of +3.4 V to +5.5 V to the central pin with the maximum antenna current equal to 120 mA.
- For powering an LNA of the GNSS antenna connected to J101, the board supplies a voltage in the range of +4.8 V to +5.16 V to the central pin with the maximum antenna current equal to 120 mA.
- Antenna’s LNA gain should be in the range of 26 dB to 34 dB.
- The total attenuation of a cable running between the antenna and the B125 should not be more than 10–12 dB at 1.6 GHz.

- Antenna's VSWR should be  $\leq 2:1$ .
- Impedance should be 50 Ohm.
- The J100 connector corresponds to the `int` value of the GRIL parameter `/par/ant/rcv/inp` and to the **Internal** value of the *GNSS Antenna* setting on the *Antenna* tab of Tracking & Positioning in the TRU software. The J101 connector corresponds to the `ext` value of the GRIL parameter `/par/ant/rcv/inp` and to the **External** value of the *GNSS Antenna* setting on the *Antenna* tab of Tracking & Positioning in the TRU software.
- The B125 uses only one connector at a time. If you attach each connector to a separate antenna simultaneously, the board will by default use the satellite signals received from the antenna connected to J100. You can activate the J101 connector using the GRIL command `%%set,/par/ant/rcv/inp,ext`. To revert to the default connector J100, use the command `%%set,/par/ant/rcv/inp,int`.
- Antenna connectors J100 and J101 provide the same tracking performance and you can choose whichever you prefer. However, bear in mind that the antenna connected to J101 requires a 5 V supply voltage as described on [page 8](#) and the parameter `/par/ant/rcv/inp` set to `ext`.
- Do not connect J100 with J101.



When you are integrating the B125 to your final product, great care should be taken to shield GNSS antenna, its connectors and RF cables within the enclosure from other electronic equipment within the same enclosure.

The B125 board incorporates antenna detection circuitry, which senses the amount of current supplied to the antenna's LNA. This circuitry indicates one of the two conditions:

- not overloaded – the antenna draws normal current or is not connected to the board.
- overload – the antenna draws current higher than expected. This condition occurs when the B125 board is subjected to a load (i.e., antenna) larger than it was designed for. It could also be reported when a short circuit occurs in the antenna, antenna cable, or the board.  
When an overload condition is detected, the board maintains a constant, safe level of output current until the overload condition is removed.

#### Further Reading:

- Details about the GNSS antenna connectors in ["GNSS Antenna Connectors"](#) on [page 48](#).
- Overcurrent values used to trigger the overload condition in ["Board Specifications"](#) on [page 41](#).

## UART

The B125 board features six UART interfaces:

- two UARTs are connected to an RS-232 transceiver (U524, ISL4245EIRZ from Intersil) and then routed to the J500 connector. You can connect these UARTs directly to RS-232 compliant devices.
  - serial interface A with flow control
  - serial interface B without flow control
- four LVTTTLs are connected directly to the J500 connector. External RS-232 transceivers are required if you want to translate these signals to the standard RS-232 voltage levels. The evaluation board uses the RS-232 transceivers MAX3225EEAP+ from Maxim Integrated.
  - serial interfaces C, D, and E with flow control
  - serial interface F without flow control

The RS-232C and LVTTTL interfaces support data rates up to 460.8 Kbit/s.

The serial interface E (UART5) and the [CAN interface](#) share the same pins and can be selected with jumpers as shown in ["Jumpers"](#) on [page 32](#).



Serial ports A, B, and C (UART3) are the only ports you can use for control and data transfer. Ports D (UART4), E (UART5), and F (UART6) are used for internal communications.

**Table 10. B125 UART Signals**

Pin No.	Signal Name	I/O	Signal Level	Description
23	UART3_TXD	O	LVTTTL	Serial data output from UART 3
24	UART3_RXD	I	LVTTTL	Serial data input to UART 3
25	UART3_RTS	O	LVTTTL	UART 3, Request to Send
26	UART3_CTS	I	LVTTTL	UART 3, Clear to Send
31	RS_TXDB	O	RS-232	Serial data output from port B
32	RS_RXDB	I	RS-232	Serial data input to port B
35	RS_RTSA	O	RS-232	Port A, Request to Send
36	RS_CTSA	I	RS-232	Port A, Clear to Send
37	RS_TXDA	O	RS-232	Serial data output from port A
38	RS_RXDA	I	RS-232	Serial data input to port A
47	UART4_RTS	O	LVTTTL	UART 4, Request to Send
49	UART4_RXD	I	LVTTTL	Serial data input to UART 4
51	UART4_TXD	O	LVTTTL	Serial data output from UART 3
53	UART4_CTS	I	LVTTTL	UART 4, Clear to Send
55	UART5_TXD	O	LVTTTL	Serial data output from UART 5
57	UART5_RXD	I	LVTTTL	Serial data input to UART 5
59	UART6_TXD	O	LVTTTL	Serial data output from UART 6
61	UART6_RXD	I	LVTTTL	Serial data input to UART 6
71	CAN_TX/UART5_RTS	O	LVTTTL	CAN Transmit/UART 5, Request to Send
72	CAN_RX/UART5_CTS	I	LVTTTL	CAN Receive/UART 5, Clear to Send

**Further Reading:**

- General design guidelines in ["General Guidelines"](#) on page 23.
- An example of how the UART interfaces connect to the 9-pin D-shell male connectors on the B125EVb in ["UART Interfaces"](#) on page 37.
- GRIL commands used to configure UARTs in the [GRIL Reference Manual](#).

**USB**

The B125 incorporates one USB 2.0 host controller, one USB 2.0 device controller, and a USB 2.0 transceiver chip (U506, TUSB1210BRHBR from Texas Instruments). The transceiver is connected to the USB controllers through a ULPI interface.



A USB host functionality is currently disabled. It will be enabled through a future firmware update.

The USB 2.0 host interface supports high-speed (480 Mbps), full-speed (12 Mbps), and low-speed (1.5 Mbps) data rates.

The USB 2.0 device (peripheral) interface supports high-speed and full-speed data rates.



The actual speed of data transfer over the USB interface is normally slower than the speed of the USB specification. This is dictated by various factors, including the board's processor loading, the performance of a host (usually, a computer), etc.

The host interface enables USB peripherals, such as USB flash memory devices to connect to the B125 board for data exchange. In host mode, you need to provide a 5V input on the +5V pin (no. 1) of the interface connector J500. The USB interface will then provide a current-limited 5V output (500 mA) on the USB\_PWR pin (no. 48) of the interface connector J500.

The device interface enables a USB host, such as a computer to connect to the B125 board for configuration and data exchange. In device mode, you need to install a USB driver onto a computer and provide a 5V input on the +USB\_PWR pin (no. 48) of the interface connector J500 to power the USB device interface.

The USB interface operates in host mode when the GPIO5 pin is pulled-up by the 10 KOhm resistor to 3.3 V. In device mode, the GPIO5 pin must be pulled-down by the 10 KOhm resistor to GND.



Make sure the B125 board is turned off when you switch between host and device modes.

Table 11 shows the USB signals and their functions.

**Table 11. B125 USB Signals**

Pin No.	Signal Name	I/O	Signal Level	Description
1	+5V	I	+5V	+5V, Power supply to USB host and GNSS antenna at J101
44	USB_D-	I/O	TTL	USB data minus
46	USB_D+	I/O	TTL	USB data plus
48	USB_PWR	I/O	+5V	+5V@500mA output in host mode +5V input in device mode

#### Further Reading:

- General design guidelines in ["General Guidelines" on page 23](#).
- Guidelines about USB host/device in ["USB" on page 23](#).
- An example of how the USB interface connects to the USB connector in ["USB" on page 38](#).
- A description of the file system in ["File System" on page 20](#).
- GRIL commands used to configure the B125 to record, store, and transfer TPS data files to and from the USB flash memory devices in the [GRIL Reference Manual](#).

## CAN

The Controller Area Network (CAN) is a serial communication protocol that allows multiple devices to communicate with one another using a common pair of wires. It has a high-integrity and high-performance architecture resistant to harsh environments. Because of these features CAN is now widely used in various embedded control applications. This protocol has been standardized internationally by the ISO (International Organization for Standardization).

The B125 board incorporates one CAN controller embedded to the Vanguard™ chip. The CAN controller conforms to the CAN specification 2.0 A/B and provides output of two NMEA 2000 messages, specifically PGN 129029 (GNSS Position Data) and PGN 129025 (GNSS Position Rapid Update).

The RX and TX lines of the CAN controller are extended directly to the interface connector J500 where the lines are shared with the [serial interface E](#) (UART5 RTS/CTS). You can select the functionality of these pins using jumpers as shown in ["Jumpers" on page 32](#).

**Table 12. B125 CAN Signals**

Pin No.	Signal Name	I/O	Signal Level	Description
71	CAN_TX/UART5_RTS	O	LVTTTL	CAN Transmit/UART 5, Request to Send
72	CAN_RX/UART5_CTS	I	LVTTTL	CAN Receive/UART 5, Clear to Send

To connect the CAN controller to the CAN bus line, you must use an external CAN transceiver. The evaluation board uses the CAN transceiver SN65HVD230QD from Texas Instruments.



**Further Reading:**

- General design guidelines in ["General Guidelines" on page 23](#).
- How to configure various CAN settings, including the baud rate and node addresses, output of NMEA 2000 messages, etc., in the [GRIL Reference Manual](#).
- An example of how the CAN interface connects to a 9-pin D-shell female connector on the B125EVb in ["CAN" on page 39](#).

## Ethernet

The B125 features an Ethernet interface, which contains the Microchip LAN8720Ai-CP-TR Ethernet PHY transceiver (U400) connected via an RMI interface to the MAC in the Vanguard chip. The LAN8720Ai-CP-TR is a full-duplex 10-BASE-T/100BASE-TX transceiver and supports 10Mbps (10BASE-T) and 100Mbps (100BASE-TX) operation. It complies with the IEEE 802.3-2005 standards and implements autonegotiation to automatically determine the best possible speed and duplex mode of operation and can be used with direct connect or cross-over LAN cables.



A remote firmware update in the B125 requires support of Ethernet and SD card. The B125 uses Ethernet to copy the firmware file to the SD card using Topcon Data Transfer Protocol or FTP. The firmware update procedure is described in the [B125 Maintenance Guide](#).

**Table 13. B125 Ethernet Signals**

Pin No.	Signal Name	I/O	Signal Level	Description
7	TXN	O		Ethernet TX negative output
8	3V3_LAN	O	0...+3.3V	Ethernet power
9	TXP	O	0...+3.3V	Ethernet TX positive output
10	ETH_LED1	O	0...+3.3V	Ethernet LED activity indicator, active-low
13	RXN	I		Ethernet RX negative input
15	RXP	I		Ethernet RX positive input

The B125 Evaluation Board provides an RJ45 connector with discrete magnetics isolation module HX0068ANL from Pulse Electronics for 10/100 Mbit Ethernet.

**Further Reading:**

- A description of supported network services and protocols in ["Network Services and Protocols" on page 19](#).
- General design guidelines in ["General Guidelines" on page 23](#).
- Design guidelines about Ethernet in ["Ethernet" on page 23](#).
- An example of how the Ethernet interface connects to the RJ45 connector in ["Ethernet" on page 38](#).
- GRIL commands to configure various network features and protocols in the [GRIL Reference Manual](#).

## 1PPS

Modern synchronization and time transfer applications require a highly-reliable timing source. The B125 delivers the 1PPS (pulse-per-second) signals that provide a very accurate reference source for external devices. You can program the period, offset, edge, and time reference of the 1PPS signal using the GRIL commands. The board accommodates a single 1PPS output which is available through pin no. 29 of the interface connector J500.

**Further Reading:**

- General design guidelines in ["General Guidelines" on page 23](#).
- Details on configuring the 1PPS functionality in the [GRIL Reference Manual](#).
- Specifications about the 1PPS signal, in ["Board Specifications" on page 41](#).

## Event Marker

The B125 can accurately record the time that an external event occurs in the specified reference time. You can program the period, offset, edge, and reference time of the event marker signal using the GRIL commands. The source of events may be a digital camera, sounding equipment, etc. The board accommodates a single event input which is available through pin no. 50 of the interface connector J500.

### Further Reading:

- General design guidelines in ["General Guidelines" on page 23](#).
- Details on configuring the event marker functionality in the [GRIL Reference Manual](#).
- Specifications about the event marker signal in ["Board Specifications" on page 41](#).

## SD/SDIO

The B125 boards includes an SD/SDIO host controller to interface with an SD/SDHC memory card for TPS data recording, storage, and firmware update.



The firmware update in the B125 requires support of the SD card. The B125 uses the SD card to store the firmware file. The firmware update procedure is described in the [B125 Maintenance Guide](#).

The controller supports 1-bit protocol (one data channel) and 4-bit protocol (four data channels) with a built-in 512-byte buffer for read and write.

The signal levels of the host controller are shifted from 1.8 V on the board to 3.3 V at the J500 connector by the voltage-translation transceiver U513, TXS0206YFPR from Texas instruments.

**Table 14. B125 SD/SDIO Signals**

Pin No.	Signal Name	I/O	Signal Level	Description
54	SDAT0B	I/O	3.3V	SD read/write data line 0
58	SDAT1B	I/O	3.3V	SD read/write data line 1
62	SDAT2	I/O	3.3V	SD read/write data line 2
63	SDWP	I	3.3V	SD write protect; internally pulled-up to 1.8V with a 100 KOhm resistor
65	SDPWR	O	3.3V	Power +3.3V
66	SDAT3	I/O	3.3V	SD read/write data line 3
67	SDCD	I	3.3V	SD card detect; internally pulled-up to 1.8V with a 100 KOhm resistor
69	SDCMDB	I/O	3.3V	SD command/response
70	SDCLKB	O	3.3V	SD clock

### Further Reading:

- A description of the file system in ["File System" on page 20](#).
- General design guidelines in ["General Guidelines" on page 23](#).
- Guidelines about SD/SDIO in ["SD/SDIO" on page 24](#).
- SD cards approved for use in ["Approved SD Cards" on page 24](#).
- An example of how the SD/SDIO interface connects to the SD card slot in ["SD Card" on page 39](#).
- GRIL commands to record, store, and transfer TPS data files in the [GRIL Reference Manual](#).

## General Purpose I/O

The B125 board provides five dedicated GPIO signals with particular functions assigned to them. GPIO1\_LED through GPIO4\_LED are configured as outputs and GPIO5 as input/output. These GPIOs are not user-configurable. Table 15 lists GPIO signals and functions assigned to them.

**Table 15. B125 GPIO Signals**

Pin No.	Signal Name	I/O	Signal Level	Description
33	GPIO1_LED	O	0...+3.3V	STAT LED, blue color; active-high, forward current 12 mA
39	GPIO2_LED	O	0...+3.3V	STAT LED, green color; active-high, forward current 12 mA
40	GPIO3_LED	O	0...+3.3V	STAT LED, red color; active-high, forward current 12 mA
41	GPIO4_LED	O	0...+3.3V	REC LED, green color; active-high, forward current 12 mA
43	GPIO5	I/O	0...+3.3V	Input: USB host/device mode Output: REC LED, red color; active-high, forward current 4 mA

Although you can drive STAT and REC LEDs directly from these GPIOs through series resistors, it is highly recommended that you add buffers for ESD protection as shown in the evaluation board schematics on [page 50](#).

### Further Reading:

- For STAT LED blinking patterns and colors, see ["STAT LED" on page 9](#).
- For REC LED blinking patterns and colors, see ["REC LED" on page 10](#).

## Function Control

The FN\_BTN\* signal (pin no. 19 on J500) is an active-low input that performs multiple functions depending on how long the signal is LOW (GND).

**Table 16. FN Functions**

Function	Duration of LOW state
Start/stop data recording to file(s)	More than 1 second and less than 5 seconds
Toggle occupation mode between static and dynamic	Less than 1 second while the file(s) is open <sup>a</sup>
Turn the baud rate of serial port A to 9600 bps	More than 5 seconds and less than 8 seconds
No action	More than 8 seconds

a. Occupation mode switch is selected in TRU.

You can also clear the NVRAM, set all parameters to default values, and power cycle the board using a combination of PBTN\* and FN\_BTN\*. Here is how you can do this:

- Pull the PBTN\* signal LOW (GND) for more than 3 seconds and less than 10 seconds to turn the board off.
- Pull the FN\_BTN\* signal LOW (GND).
- Pull the PBTN\* signal LOW (GND) for about one second. Pull the PBTN\* signal HIGH (3.3V) while continuing to hold the FN\_BTN signal LOW.
- Wait until the STAT and REC LEDs are green.
- Wait until the STAT and REC LEDs blink orange.
- Pull the FN\_BTN signal HIGH (3.3V) while the STAT and REC LEDs blink orange.

The FN\_BTN\* signal has an on-board pull-up resistor of 100 KOhm to 3.3 V and can be left unconnected if unused.

## Firmware Features

### Real-Time Kinematic Engine

The B125 board incorporates a highly innovative RTK engine developed at Topcon. It offers a host of new features and benefits blended with exceptional processing power. With the new RTK engine, the B125 provides unrivaled positioning system efficient, secure, and appropriate for any real-time application that requires accurate positioning solutions.

The following are some of the unique abilities available in the Topcon's proven RTK engine.

- Designed for world-wide use and ready for GNSS challenges of the field
- A greatly reduced amount of time needed for getting a fix
- Perfectly tailored to both network and single reference station RTK techniques
- Well suited for all kinds of baselines (short, medium, long)
- Continuous monitoring, catching and removing measurement anomalies to secure reliable positioning
- Carefully geared to handle up to 1 minute data-link delays
- Selecting among different linear combinations of observations
- New GNSS observations, such as L1C and L2C, as well as BeiDou B1/B2 and SBAS L1 are readily and seamlessly accommodated
- Instant controllability and flexibility that lets you optimize the engine performance over an extensive set of commands
- A variety of advanced options, specifically: a dedicated minimal signal-to-noise ratio for each satellite signal; feeding the engine with various observations; number of ambiguity subsets resolved per epoch, and more.

#### Further Reading:

GRIL commands for RTK base/rover in the [GRIL Reference Manual](#).

### Network-based RTK Techniques

The RTK engine in the B125 board supports three widely used network RTK implementation techniques, specifically, VRS, FKP, and MAC.

**Virtual reference station (VRS).** The network software collects raw data measurements from several reference stations that belong to a network. These data are then estimated and processed to produce ionospheric and tropospheric corrections for each station and each satellite. After the rover receiver transmits its approximate position to the network software using an NMEA GGA message, the corrections are interpolated to the position of the rover. Interpolated corrections are used to reconstruct the measurements of pseudo range and carrier phase of a virtual reference station located close to the rover. The reconstructed measurements are transmitted to the rover as RTCM or CMR messages.

#### Further Reading:

GRIL commands for VRS rover mode in the [GRIL Reference Manual](#).

**Area correction parameters (FKP).** Unlike the VRS approach, the network software calculates coefficients for modeling ionospheric, tropospheric, and orbital effects for each satellite over a specific network area. The coefficients are then transmitted to the rover as RTCM message type 59, so that the rover can generate the corrections and apply them to its own observations to compute the position with high accuracy.

#### Further Reading:

GRIL commands for FKP rover mode in the [GRIL Reference Manual](#).

**Master-auxiliary concept (MAC).** This approach assumes the usage of one master reference station and a number of auxiliary reference stations to generate network correction messages. The master station transmits full raw observations and coordinate information while auxiliary stations transmit ionospheric and geometric correction differences and coordinate differences calculated between the master and each auxiliary station. The rover accepts all these data as RTCM 3 messages and applies them to get its own accurate position.

**Further Reading:**

GRIL commands for MAC rover mode in the [GRIL Reference Manual](#).

## Precise Point Positioning Engine

Precise Point Positioning (PPP) is a method that provides decimeter to centimeter level positioning accuracies using a dual-frequency GNSS receiver without the need of reference receivers and communication data link. The PPP method stems from the emergence of precise satellite orbit and clock corrections produced by IGS and other organizations for distribution to PPP-enabled receivers via the L-band satellite downlink or Internet. The Topcon PPP engine, namely TopNET Global -D, running in the B125 combines the received orbit and clock corrections with ionosphere-free code and carrier phase measurements to achieve a truly global, seamless, high-accuracy position.

**Further Reading:**

GRIL commands for PPP mode in the [GRIL Reference Manual](#).

## Enhanced Positioning Engine (DION)

DION is an enhanced absolute positioning engine that allows you to use a single B125 to compute smoothed and consistent position solutions. Instead of using instantaneous yet rather noisy pseudorange measurements of an ordinary single point positioning, you can activate the DION engine to get more accurate and reliable results without the requirement of any additional hardware or software. What sets DION apart from other positioning engines is an innovative approach to combining the simplicity and availability inherent in the absolute positioning with the reliability and accuracy of the relative positioning.

Currently DION can be used in standalone and DGPS positioning modes. You can also enable it on a TPS receiver acting as a moving RTK base.

DION has two modes of operation:

- Smooth mode, used when you need to get a smooth variation of absolute or DGPS positions. In this mode, the absolute and DGPS positions obtained from pseudorange measurements will be smoothed by the refined delta positions obtained from the corresponding carrier phase measurements thus reducing the noise level of pseudorange measurements and removing position jumps.
- Local mode, used when you need to get a stable pass-to-pass accuracy at the decimeter level. This mode is ideal for applications where a vehicle (e.g., tractor) must follow and replicate the designated route. Local mode requires coordinates of the starting point entered in the B125.

**Further Reading:**

GRIL commands for DION mode in the [GRIL Reference Manual](#).

## Satellite Based Augmentation System (SBAS)

SBAS is designed to improve the accuracy and availability of, as well as ensure the integrity of, information broadcast from GPS satellites. It works by providing a net of ground stations that receive GPS signals, generating correction messages and uploading them to geostationary satellites. These correction messages are then broadcast to a GPS receiver using the GPS L1 frequency. The receiver applies these messages to correct for various errors that affect the measurements. In addition, the geostationary satellites can be used for positioning as ordinary GPS satellites, improving system availability.

The B125 supports the following SBAS services:

- The Wide Area Augmentation System (WAAS) – developed and operated by the Federal Aviation Administration (FAA) in the United States. WAAS uses two geostationary satellites, Galaxy 15 (PRN 135) and Anik F1R (PRN 138) to broadcast correction messages over the majority of the continental U.S. and large parts of Canada, Alaska, and Mexico. The system is fully operational and delivers submeter position accuracy provided all WAAS corrections for at least four GPS satellites are available.
- The European Geostationary Navigation Overlay Service (EGNOS) – developed and operated by the European Space Agency (ESA), the European Commission (EC), Eurocontrol, and the European Organization for the Safety of Air Navigation. EGNOS uses three geostationary satellites—AOR-E (PRN 120), ARTEMIS (PRN 124), and IOR-W (PRN 126)—to broadcast correction messages. Starting with 2 March 2011, EGNOS is fully operational and delivers submeter position accuracy using Open and Safety-of-Life services.
- The Multi-functional Satellite Augmentation System (MSAS) – developed and operated by the Japan Civil Aviation Bureau (JCAB) for civil Aviation and Meteorological Agency. MSAS uses two geostationary satellites, MTSAT-1R (PRN 129) and MTSAT-2 (PRN 137), to broadcast correction messages.

#### Further Reading:

- Official information on WAAS at the GPS.gov website ([www.gps.gov](http://www.gps.gov)).
- Official information on EGNOS at the ESA website ([http://www.esa.int/Our\\_Activities/Navigation/The\\_present\\_-\\_EGNOS/What\\_is\\_EGNOS](http://www.esa.int/Our_Activities/Navigation/The_present_-_EGNOS/What_is_EGNOS)).
- Official information on MSAS at the Japan Meteorological Agency website (<http://www.jma.go.jp/jma/jma-eng/satellite/index.html>).
- GRIL commands for SBAS in the [GRIL Reference Manual](#).

## Quartz Lock Loop

GNSS receivers are often deployed in high-vibration environment such as machine control and construction equipment. In these severe environmental conditions, shock and vibration can cause significant frequency shifts in the receiver's quartz crystal. Such large frequency excursions degrade the receiver performance, leading to difficulties in maintaining continuous tracking of the satellite signals.

Topcon's Quartz Lock Loop (QLL) technology minimizes the vibration-induced impact through permanent monitoring, detection, and isolation of the frequency deviations thus improving survivability and performance of the B125 in dynamic applications.

#### Further Reading:

Details on how to enable QLL in the [GRIL Reference Manual](#).

## Network Services and Protocols

With the diversity of network services and protocols available in the B125, you can easily and seamlessly integrate the board to your network and communicate to the board over TCP/IP from any host located anywhere in the world. All these network features are fully programmable with the GRIL commands.

### TCP Client/Server

In TCP Client mode, the board will initiate a connection to a remote TCP server at a specific IP address and Port number. TCP client can handle only one connection at a time.

In TCP Server mode, the board will listen on a specific TCP port waiting for a remote client to establish a connection to it. TCP server can handle up to 10 concurrent TCP connections.

#### Further Reading:

GRIL commands for TCP Client/Server in the [GRIL Reference Manual](#).

### FTP Client/Server

You can configure your board to send and receive files across TCP/IP networks using the file transfer protocol (FTP). The B125 can act as an FTP client or server.

The FTP server on the B125 provides access to the board's file system in read-only mode. Up to five simultaneous connections to the FTP server are supported. Through these connections you can download files from the board.

Using the B125 as an FTP client, you can automatically upload files to an FTP server.

#### Further Reading:

GRIL commands for FTP Client/Server in the [GRIL Reference Manual](#).

### DNS Server

DNS (Domain Name System) is a distributed database of host names and their associated IP addresses. Using DNS you can type simple names, such as [www.topcon.com](http://www.topcon.com) to refer to a host, rather than typing its IP address (e.g., 211.132.11.29). For this, you need to specify the IP address of an external DNS server that the B125 will query to look up the IP address assigned to the requested host name.

#### Further Reading:

GRIL commands for DNS server in the [GRIL Reference Manual](#).

### DHCP Client

The Dynamic Host Configuration Protocol (DHCP) is the host configuration protocol that provides an automated method for dynamic IP address allocation and delivery of host-specific configuration parameters from a DHCP server to a host (i.e., to the B125 board configured as a DHCP client).

#### Further Reading:

GRIL commands for DHCP client in the [GRIL Reference Manual](#).

### Ntrip Protocol

Networked Transport of RTCM via Internet Protocol (Ntrip) is an effective method for streaming realtime GNSS data to stationary or mobile receivers over the Internet. Ntrip uses the Hypertext Transfer Protocol (HTTP/1.1) and the Real Time Streaming Protocol (RTSP) as the application level protocols.

The B125 firmware supports versions 1.0 and 2.0 of the Ntrip protocol with NtripServer, and NtripClient components implemented.

The complete description of the Ntrip protocol is outside the scope of the guide. Visit the Publications section of the RTCM website at [www.rtc.org](http://www.rtc.org) for a comprehensive documentation of the protocol.

In addition, the Bundesamt für Kartographie und Geodäsie (BKG) (Federal Agency of Cartography and Geodesy) GNSS Data Center website contains reference information about Ntrip, including documentation, software, etc. To access the Ntrip area of the BKG's GNSS Data Center website, go to <http://igs.bkg.bund.de/ntrip/ntriphompage>.

#### Further Reading:

GRIL commands for Ntrip in the [GRIL Reference Manual](#).

## File System

The B125 board records TPS data to a storage medium with a file system in which files and folders are organized in a hierarchical structure for storage and retrieval. As a storage medium, the B125 supports [SD/SDHC cards](#) and [USB flash memory devices](#). You can also transfer files to FTP servers.

A storage medium must be formatted to a [FAT32](#) file system. The capacity of a storage medium is limited to 32 GB. You can record TPS data to up to a maximum of 16 simultaneous files at the rates shown in Table 17.

**Table 17. Recording Rates vs Number of Simultaneous Files**

<b>Recording Rate, Hz</b>	20	10	5	2	1
<b>Simultaneous Files</b>	1	≤2	≤4	≤10	≤16

The B125 supports faster recording rates (up to 100 Hz) but this may lead to a high CPU usage, which in turn will likely affect the overall performance of the board, including the positioning engines and the integrity of recorded files. To reduce the CPU usage and ensure the highest possible data recording rate, consider the following guidelines:

- Set the position update rate to a minimum, for example, 1 second.
- Change the maximum number of satellites used in positioning from the default of 64 to a lower number, for example, 15.
- Configure the board to track only relevant satellite measurements for your application.
- Optimize the number of recorded messages by excluding messages that are unnecessary for your application.

A total of 3000 files can be recorded and stored on each storage medium. When no memory remains, you can program the B125 to remove the oldest files automatically to make room for the newest files without having to replace the storage medium. You can also instruct the board what to do with data recording in the event of power failure.

The files that reside on the storage medium can be accessed and transferred to a computer via serial, USB, and Ethernet ports of the B125 board. You can also access the files by connecting the SD/SDHC card or USB memory device to a Windows computer and using Windows Explorer or any other file utility to copy and delete the files from them.

#### Further Reading:

- Storage medium details in ["USB" on page 12](#) and ["SD/SDIO" on page 15](#).
- SD cards approved for use in ["Approved SD Cards" on page 24](#).
- GRIL commands used to configure the B125 to record, store, and transfer TPS data files in the [GRIL Reference Manual](#).

## Option Authorization File (OAF)

Topcon Positioning Systems issues an Option Authorization File (OAF) to enable the specific options that customers purchase. An Option Authorization File allows customers to customize and configure the board according to particular needs, thus only purchasing those options needed.

Typically, all boards ship with a temporary OAF that allows it to be used for a predetermined period of time. When the board is purchased, a new OAF permanently activates desired, purchased options. The options remain intact when clearing the NVRAM or resetting the board.

The OAF enables the following kinds of functions. For a complete list of available options and details, visit the TPS website or consult your TPS dealer.

- Type of signal (standard L1 GPS; optional L2, GPS, GLONASS, GALILEO, BeiDou)
- Update rate standard 20 Hz (optional 100 Hz)
- RTK at 1, 5, 10, and 20 Hz
- RTCM/CMR Input/Output
- 1PPS and Event Marker
- Quartz-locked loop
- Advanced multipath reduction
- Satellite Based Augmentation System (WAAS/EGNOS/MSAS)
- DION positioning
- RS-232C and USB port connectivity



## Design Guidelines

### Board Orientation and Mounting

The B125 board can be installed in any number of orientations within an enclosure. The board will operate and meet all specifications regardless of the mounting orientation.

The board has four mounting holes to install M2 metric machine screws. Always secure the board using all four mounting holes.

Care should be taken that the recommended tightening torque does not exceed 700 N/m (4 lbf/in).

#### Further Reading:

For mechanical layout, see [“Mechanical and Schematic Drawings”](#) on page 49.

### Pin Numbering and Connectivity to Target Hardware

Make sure you attach the J500 connector to your target hardware properly. The J500 connector is unkeyed, which means that a potential risk exists to attach it to the mating connector backward.

To avoid attaching the connectors incorrectly, locate pin nos. 1, 2, 79, and 80 on the B125 as shown in Table 18 and make sure that these pins attach to the mating connector in your target hardware properly oriented.

**Table 18. J500 Pin Locations**

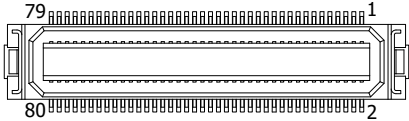
Pin No.	On-board Label	Location	Drawing
1	1	top-right	 <p>Also see <a href="#">“Interface Connector”</a> on page 45.</p>
2	2	bottom-right	
79	79	top-left	
80	not labeled	bottom-left	

The following figure shows you how the J500 connector on the B125 attaches to the mating connector on the B125EVB evaluation board.

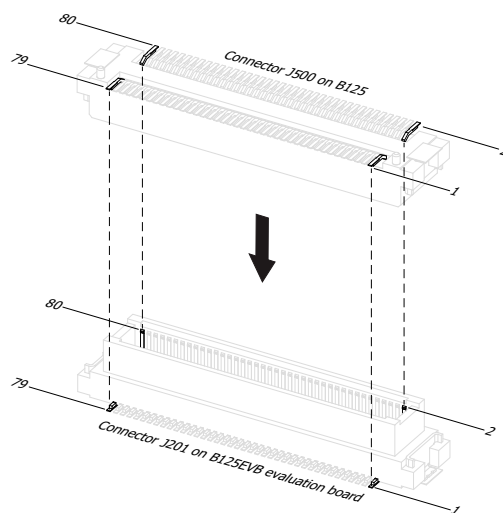

**Figure 4: Pins Orientation**

### Cooling/Heating Requirements

The board does not require any special thermal management when using within the operating temperature range. However, if you expect to use the board outside the specified operating range, you must provide adequate cooling/heating to maintain proper thermal management of the board.

#### Further Reading:

[“Board Specifications”](#) on page 41 for operating and storage temperature ranges.

## General Guidelines

- The J500 connector provides 14 ground pins. Ensure that all of them are connected to a solid ground plane.
- Always power off the B125 and B125EVB before connecting/disconnecting cables, SD cards, and jumpers.
- Identify pin no. 1 of each interface or jumper by looking at the back side of the B125EVB. Pin no. 1 is always marked by a square soldering pad.

## Power

When designing a power supply for the B125, observe the following guidelines to ensure secure and continuous operation of all system components:

- Make sure that the total impedance of the power source is below 100 mOhm.
- The response time of the power source must be as quick as possible.
- Use decoupling capacitors to deliver high peak current pulses without too much drop in the input voltage.
- For the correct power-up sequence, the B125 must be powered up before any connected peripheral devices receive power.
- For the correct power-down sequence, remove power from any connected peripheral devices, then power down the B125.

## USB

Observe the following guidelines for connecting a USB2.0 PHY transceiver chip to an external USB mini-AB connector using the USB interface signals of the B125 connector.

- Verify with an impedance calculator that trace spacing and trace width used on the specific board stackup results in 90 Ohm differential impedance.
- Maintain parallelism between USB differential signals needed to achieve 90 Ohm differential impedance between D+ and D- for the entire routed length.
- Minimize the length of high-speed clock and periodic signal traces that run parallel to the USB signal lines to minimize crosstalk. High speed and periodic signals should be kept at least 50 mils away from USB D+/D-.
- All other signals should be kept at least 20 mils away from the high-speed USB signal pairs to help prevent crosstalk.
- Use an external pull-down resistor of 10 kOhm for a USB device and an external pull-up resistor of 10 kOhm for a USB host.

### Further Reading:

These guidelines are also available at [www.usb.org](http://www.usb.org) in the Developers area.

## Ethernet

- The PHY transceiver on the B125 requires an RJ45 connector with integrated or external magnetics for 10/100 Mbps Ethernet.
- The distance from the B125 connector and magnetics should be as short as possible and not larger than 1 inch.
- The distance from the magnetic and an RJ45 connector should be as short as possible and not larger than 1 inch.
- Differential pair (TX+/- or RX+/-) should be routed away from all other signals and close together with 100 Ohm  $\pm 10\%$  impedance.
- Routing without vias is preferred. If the PCB layout really needs to use vias on the differential pairs, please match the vias to keep the differential pairs balanced.
- Keep both traces of each differential pair as identical to each other as possible.
- Route both TX+/- and RX+/- pairs as far as away from each other.
- Void both power and ground planes on all PCB layers directly under the magnetics.
- Chassis ground should extend from the magnetics to the RJ45 connector.

- Do not route any digital signals between the PHY and RJ45 connector.

## SD/SDIO

- Design an SD card placement as close as possible to the B125 board to minimize trace lengths from the B125 to the SD card connector. Total trace length should not exceed 5 cm (1.97 in).
- Maintain equal trace lengths.
- Trace widths should be uniform.
- Minimize signal noise and ensure signal integrity by installing series resistors of 22 to 32 Ohm on all data, clock, and command lines.
- Avoid crossing plane splits as this will degrade signal integrity and increase radiated emissions.
- Preserve data integrity by installing or removing the SD card only when the B125 board is powered off.

## Approved SD Cards

The following SD cards have been successfully tested with the B125 and can be safely used with the board. This list is regularly updated as new SD cards are tested.

- Panasonic 2GB SLC memory card (RP-SDF02GDA1)
- Panasonic 4GB SLC memory card (RP-SDF04GDA1)
- Transcend Industrial 2GB SD Card (SLC SD100I)
- Transcend Industrial 4GB SDHC Card (TS4GSDHC100I)

Many other SD cards may work but Topcon cannot guarantee their performance and reliability.

## Product Compliance

TPS does not consider the B125 to be a finished end product. The B125 must only be used for incorporation into a final product. The user is then responsible for ensuring that the final product has been tested for electromagnetic compatibility and found to comply with the regulation standards before the product can be marketed.

# Using Evaluation Board

The [development kit](#) includes the B125 evaluation board (B125EVB). The B125EVB is a hardware development platform that will help you rapidly explore and evaluate features and performance of B125 and develop hardware and software solutions for designs based on the B125 board. You can also use the evaluation board as a reference design for development of your hardware in which the B125 is installed. Complete schematics and BOM are available under a Non Disclosure Agreement (NDA) to reduce your development costs and time as well as minimize design risks and test time.



The B125EVB is designed for use in controlled laboratory environments only.

---

## Overview

The B125EVB provides the following features and communication interfaces:

- Two GNSS antenna inputs
- Interface connector for the B125
- Two power supply connectors
- Six RS-232 D-sub serial interfaces
- One USB host/device type mini-AB connector
- 10/100 Mbps RJ45 Ethernet connector
- One CAN 2.0 A/B port
- One SD slot
- One 1PPS output
- One event marker input
- Backup battery
- Four push buttons for power on, reset, and function
- Two LEDs for satellite tracking and recording files
- Five jumpers
- Two test pads and 13 test points



Observe the following safety precautions before performing any installation procedures.

Always ground yourself to remove any static electricity before you begin the installation procedure. Use a grounding wrist strap at all times.

Alternatively, you can touch an unpainted, grounded metallic surface to discharge any static charges from your body or clothing.

Place the B125, B125EVB, and other electronic components on a static-dissipative surface or in anti-static packaging when they are not in use.

Power up the B125 and B125EVB boards only after you complete all other connections. Making connections while the boards are energized can damage them.

---

# Connector and Component Locations

Figure 5 shows an annotated board layout with major components.

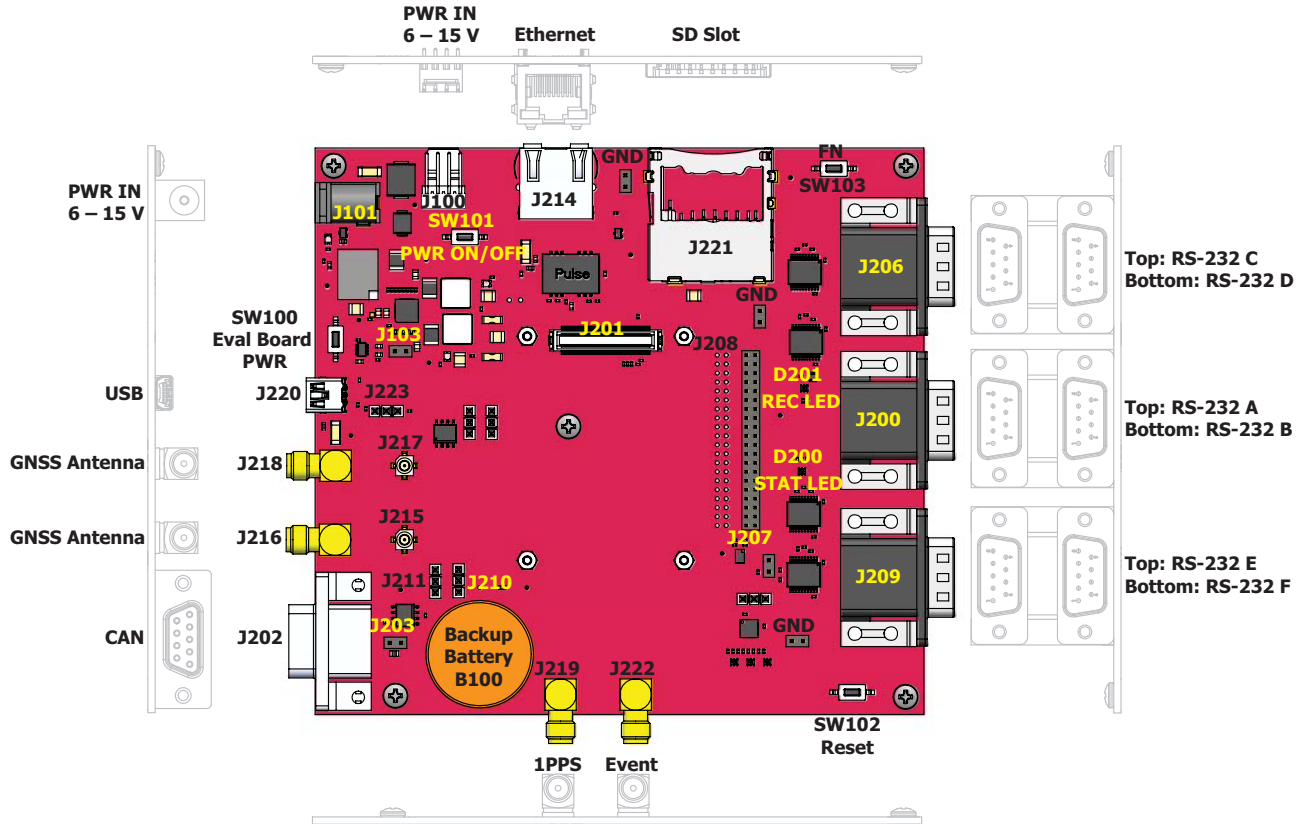

**Figure 5: B125 Evaluation Board Layout**



Hover the pointer over the desired connector or component. Once the pointer changes to a hand icon, click it. You will be automatically navigated to the page where the selected element is described in detail.

To return to the evaluation board layout figure on this page, click the evaluation board icon shown in the left margin.



## Quick-Start to Run the B125 Installed on the Evaluation Board



Before taking the procedure, make sure the following conditions are met:

- You are discharged from electrostatic charges.
- The B125 and B125EVB boards are taken out of their protective bags.
- The B125EVB is positioned on an even, concrete surface.
- An active GNSS antenna has a clear view of the sky.

1. Locate the interface connector J500 on the B125 and align it with its mating connector J201 on the B125EVB board.
2. Mount the B125 board horizontally, with the interface connector J500 side down, onto the four standoffs of the B125EVB board until it is lying flat against the B125EVB board (Figure 6).

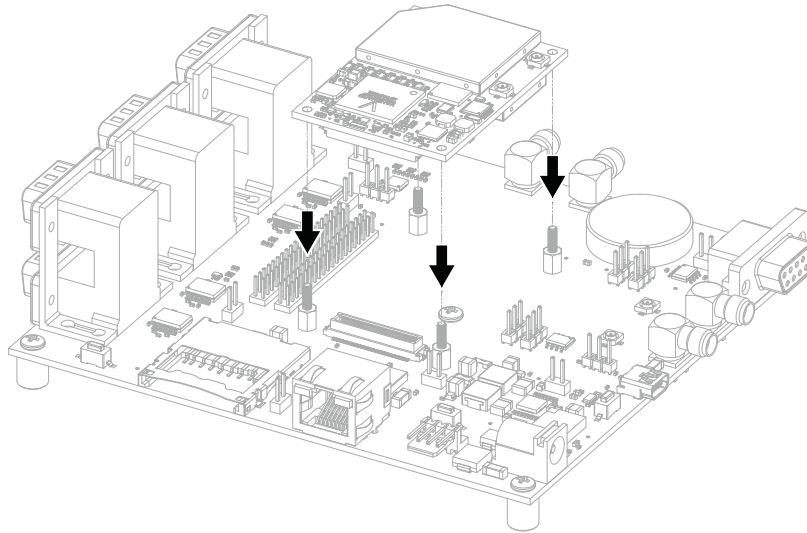

**Figure 6: Mounting the B125 onto the B125EVB**

Make sure that the B125 board is firmly seated in the place and the J500 connector is inserted to the J201 connector on the B125EVB all the way in for a secure mating contact.

3. Connect either end of the RF cable (p/n 14-004159-01LF) to the J100 connector on the B125 board. Connect the other end of the RF cable to the J217 connector on the B125EVB board.

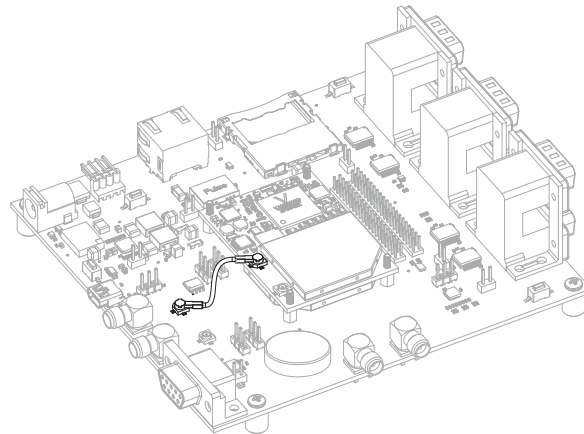

**Figure 7: Antenna Connection – J100-J217 Connection**

Make sure that you insert the RF cable all the way in.



Do not connect J100 with J215 and J101 with J217.

- Connect the SMA end of GNSS antenna cable to the J218 connector on the B125EVb board. Connect the other end of GNSS antenna cable to an active antenna.



Although the [development kit](#) includes some cables and adapters, your cabling system may require additional cable/adapters not included in the kit.

- Using a null modem cable, connect the corresponding port of your computer to the serial port A of the B125EVb. You can use a USB-to-serial port adapter, if your computer does not have a dedicated serial port.
- Connect the appropriate power supply unit to the power input J100 or J101 of the B125EVb board. Then plug the power supply to an available outlet.
- Turn on the B125 and B125EVb boards by pressing the **ON/OFF** key (SW101) for more than 1 second and less than 3 seconds until the LEDs will light up. The STAT LEDs on the B125 and B125EVb boards will start blinking for each tracked satellite as described in "[STAT LED](#)" on [page 9](#).

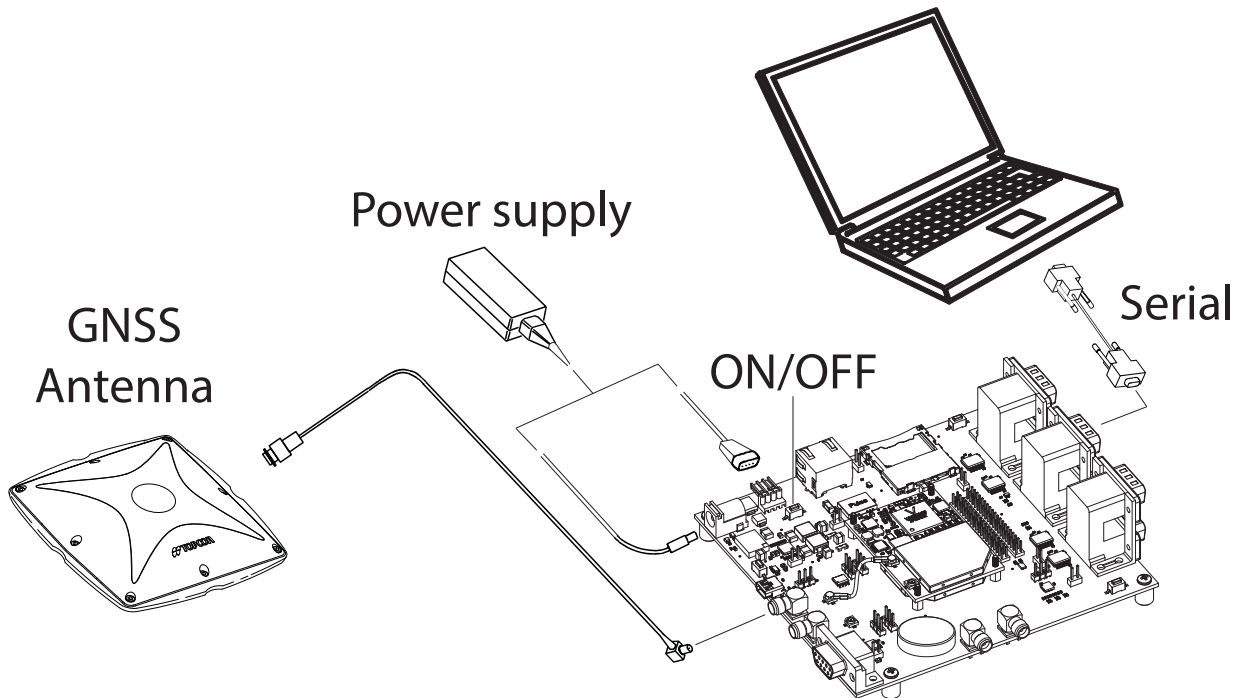
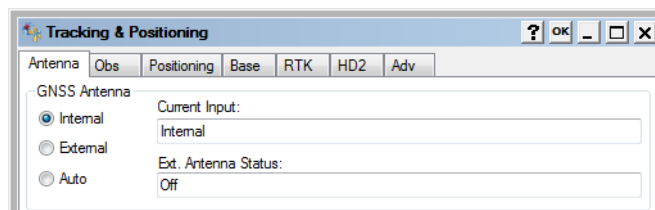

**Figure 8: Quick Connection**



Do not connect power supplies to J100 and J101 simultaneously. This might destroy the B125EVb and B125 boards.

- Run TRU, click **Device ► Connect**, select **Serial Port** in **Connect Using** and your COM port in **Port Name**. Click **Connect**.
- Click **Receiver Settings ► Tracking & Positioning**. Make sure **GNSS Antenna** on the **Antenna** tab is set to Internal and **Current Input** shows Internal.



**Figure 9: J100 Antenna Status in TRU**

Click **OK** and **Back**.

10. Click **Status**. The **Position** tab will show you the current position of the receiver's antenna and basic tracking information for locked satellites.

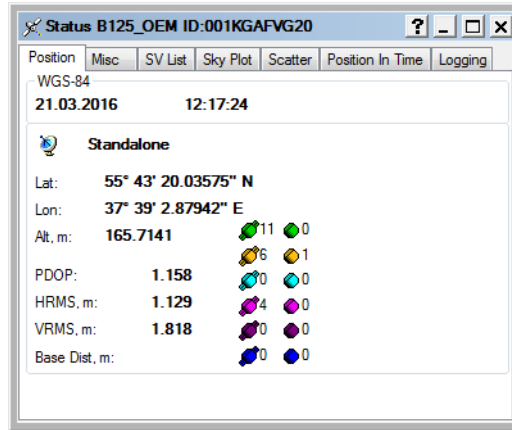

**Figure 10: Position Tab in TRU**

11. You are successfully connected to the B125 and can continue with other configuration or operation functions as needed. For further information on how to configure the B125 for various tasks using the GRIL commands, parameters, and messages, see the [GRIL Reference Manual](#) and [Maintenance Guide](#).  
To turn off the B125 and B125EVB boards, press the **ON/OFF** key (SW101) for more than 3 seconds and less than 10 seconds until the LEDs go out, then release.



The B125 takes from 30 seconds up to 120 seconds to complete the power-off sequence. During this time, the STAT LED on the B125 and the REC and STAT LEDs on the B125EVB will blink yellow. Do not disconnect the power supply until the LEDs go out.



# B125 Evaluation Board Components and Connectors

## GNSS Antenna Inputs



The B125EVB board provides two GNSS antenna inputs as shown on [Figure 11](#). Each input consists of the Hirose H.FL receptacle (J215 or J217) and the SMA R/A receptacle (J216 or J218).

The connected B125 board will use only one input at a time. The B125 board must be connected to the antenna inputs on the B125EVB as follows:

- J100(B125) ▶ J217-J218(B125EVB)
- J101(B125) ▶ J215-J216(B125EVB)

If you attach each input to a separate antenna simultaneously, the B125 board will by default use the signals received from the antenna connected via J217-J218 input.

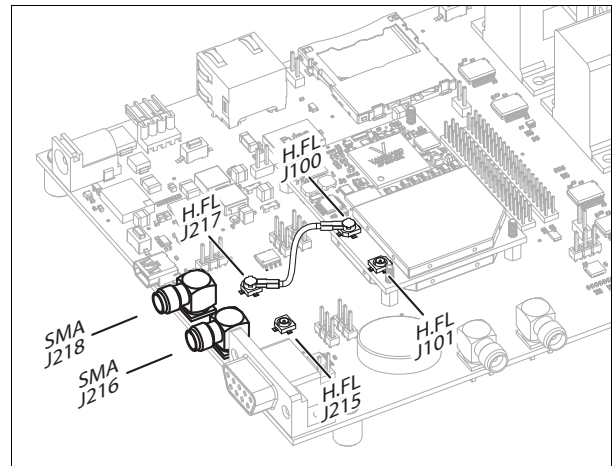

**Figure 11: Antenna Inputs**

### Further Reading:

Guidelines on how to select and use a GNSS antenna in "[GNSS Antenna](#)" on page 10.

## Power Connectors



The B125EVB operates from an external power supply connected to either the power input J100 or J101. J100 is a 4-pin, 2.5 mm pitch, Molex PCB header of 5046 series (p/n 22-05-1042). It mates with the Molex Wire-to-Board headers of 51191 series. J101 is a 2mm/6.5mm, barrel-style, 16V/2.5A, RA power jack from CUI (p/n PJ-002A). The input voltage must be in the range of +6 Vdc to +15 Vdc. The DC voltage is then reduced and is distributed to the various components on the B125EVB and B125 boards. The power supply (p/n 60815) included to the [development kit](#) connects to the power input J101. For a connection to J100, you may use a custom cable or a Molex-to-banana plugs Topcon cable (p/n 14-008021-01LF) and the appropriate power supply.

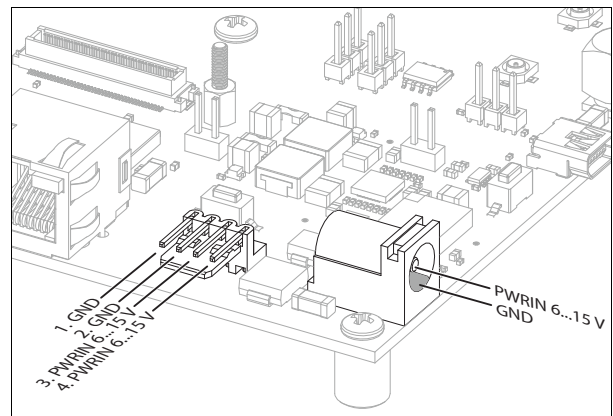

**Figure 12: Power Connectors**

The power supply rail is protected against reverse input voltage polarity with a Schottky diode.



Do not connect power supplies to J100 and J101 simultaneously. This might destroy the B125EVB and B125 boards.

## Keys



The B125EVB features four keys:

- SW100 – powers on and off the B125EVB and the connected B125 when the jumper J103 is placed over the pins. When the jumper is removed, the SW100 key is disabled.
- SW101 – powers on and off the connected B125 while leaving the B125EVB energized. It is recommended to always use this key to power on and off the B125. See [“Quick-Start to Run the B125 Installed on the Evaluation Board” on page 27](#) for how to power on/off the B125 using the SW101 key.

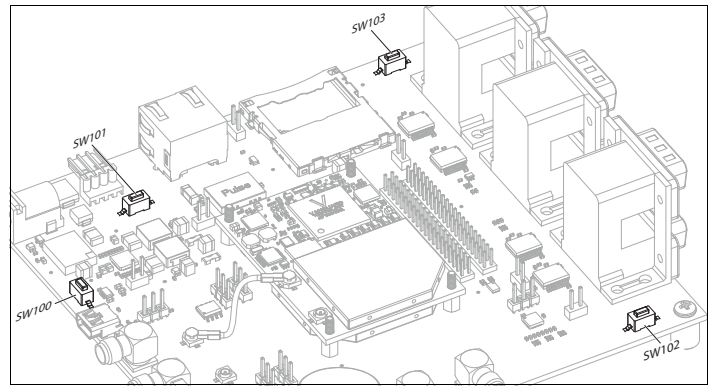

**Figure 13: Keys**

- SW102 – resets the B125 and B125EVB boards.
- SW103 – starts and stops data files, toggles occupation mode, sets the baud rate of serial port A to 9600 bps, and is used in factory reset.

Pressed for less than 1 second while the data file is open <sup>a</sup>	Toggles occupation mode between static and dynamic.
Pressed for 1–5 seconds	Starts/stops data recording to file(s).
Pressed for 5–8 seconds	Turns the baud rate of serial port A to 9600 bps.
Pressed for more than 8 seconds	No action.

a. Occupation mode switch is selected in TRU.

You can also clear the NVRAM, set all parameters to default values, and power cycle the B125 board using a combination of SW101 and SW103. Here is how you can do this:

1. Press the ON/OFF key (SW101) to turn off the B125 board.
2. Press and hold the **FN** key (SW103).
3. Press and hold the ON/OFF key for about one second. Release the ON/OFF key while continuing to hold the **FN** key.
4. Wait until the STAT and REC LEDs are green.
5. Wait until the STAT and REC LEDs blink orange.
6. Release the **FN** key while the STAT and REC LEDs blink orange.

## LEDs



The B125EVB features two LEDs:

- STAT – the STAT LED (D200) displays the status of the tracked satellites. The sequence of blinks and their colors are described in [“STAT LED” on page 9](#). The STAT LED is available through GPIO1\_LED...GPIO3\_LED signals (pin nos. 33, 39, 40) of the J500 connector on the B125 board. See [“General Purpose I/O” on page 16](#) for details.
- REC – the REC LED (D201) displays the data recording status and other memory related information. The sequence of blinks and their colors are described in [“REC LED” on page 10](#).

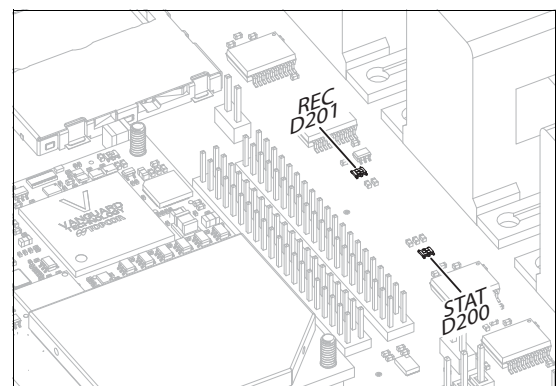

**Figure 14: STAT and REC LEDs**

## Jumpers



The B125EVB features five jumpers:

- J103 – configures the behavior of the SW100 key. When the jumper is placed over the pins, SW100 powers on and off the B125EVB and the connected B125. When the jumper is removed, the SW100 key is disabled.
- J203 – terminates the CAN\_H and CAN\_L lines of the CAN interface. Place a jumper over the pins to apply a load of 120 Ohm across the CAN data lines. If you do not need a CAN termination resistor, remove the jumper.
- J210, J211 – control the function of pin nos. 71 and 72 on the connector J500 of the B125 board. These pins can be configured for CAN TX/RX or UART5 RTS/CTS. Use of these interfaces is mutually exclusive.

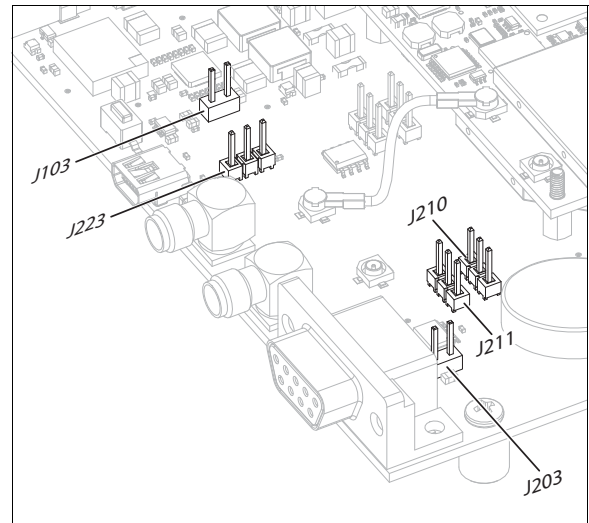

**Figure 15:** Jumpers



Both jumpers are placed over pin nos. 1 and 2 of J210 and J211. On the B125, pin no. 71 will function as CAN\_TX and pin no. 72 as CAN\_RX.



Both jumpers are placed over pin nos. 2 and 3 of J210 and J211. On the B125, pin no. 71 will function as UART5\_RTS and pin no. 72 as UART5\_CTS.



- J223 – configures the USB interface to operate in host<sup>1</sup> or device modes. Place a jumper over pin nos. 1 and 2 for host mode or over pin nos. 2 and 3 for device mode.



USB Host Mode



USB Device Mode



You can identify pin no. 1 of each interface or jumper by looking at the back side of the B125EVB. Pin no. 1 is always marked by a square soldering pad.



Before you move any jumpers, power off the B125EVB and B125.

1. A USB host functionality is currently disabled. It will be enabled through a future firmware update.

## Interface Connector



The interface connector J201 connects the B125EVb with the B125. The connector is a 80-pin header of Hirose DF17 series, part number DF17(2.0)-80DP-0.5V(57).

Table 19 gives pin assignments of the interface connector J201.

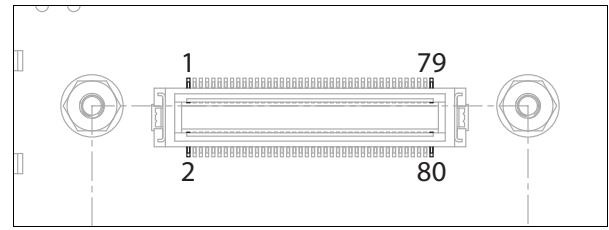

Figure 16: B125EVb Interface Connector

Table 19. Interface Connector J201

Pin No.	Signal Name	I/O	Signal Level	Description
1	+5V	I	+5V	+5V, Power supply to USB host and GNSS antenna at J101
2	PWR_IN	I	+3.4...5.5 V	Primary power supply input
3	GND		GND	Ground
4	PWR_IN	I	+3.4...5.5 V	Primary power supply input
5	GND		GND	Ground
6	PWR_IN	I	+3.4...5.5 V	Primary power supply input
7	TXN	O		Ethernet TX negative output
8	3V3_LAN	O	0...+3.3V	Ethernet power
9	TXP	O	0...+3.3V	Ethernet TX positive output
10	ETH_LED1	O	0...+3.3V	Ethernet LED activity indicator, active-low
11	GND		GND	Ground
12				Factory reserved. Leave this pin unconnected.
13	RXN	I		Ethernet RX negative input
14				Factory reserved. Leave this pin unconnected.
15	RXP	I		Ethernet RX positive input
16				Factory reserved. Leave this pin unconnected.
17	GND		GND	Ground
18				Factory reserved. Leave this pin unconnected.
19	FN_BTN*	I	0...+3.3V	Function button, active-low
20	PBTN*	I	0...+3.3V	Power button, active-low
21				Factory reserved. Leave this pin unconnected.
22	VBAT	I	0...+3.6V	Backup power supply
23	UART3_TXD	O	LVTTL	Serial data output from UART 3
24	UART3_RXD	I	LVTTL	Serial data input to UART 3
25	UART3_RTS	O	LVTTL	UART 3, Request to Send
26	UART3_CTS	I	LVTTL	UART 3, Clear to Send
27	GND		GND	Ground

Table 19. Interface Connector J201

Pin No.	Signal Name	I/O	Signal Level	Description
28				Factory reserved. Leave this pin unconnected.
29	1PPSA	O	LVTTTL	1PPS output
30				Factory reserved. Leave this pin unconnected.
31	RS_TXDB	O	RS-232	Serial data output from port B
32	RS_RXDB	I	RS-232	Serial data input to port B
33	GPIO1_LED	O	0...+3.3V	STAT LED, blue color; active-high, forward current 12 mA
34	GND		GND	Ground
35	RS_RTSA	O	RS-232	Port A, Request to Send
36	RS_CTSA	I	RS-232	Port A, Clear to Send
37	RS_TXDA	O	RS-232	Serial data output from port A
38	RS_RXDA	I	RS-232	Serial data input to port A
39	GPIO2_LED	O	0...+3.3V	STAT LED, green color; active-high, forward current 12 mA
40	GPIO3_LED	O	0...+3.3V	STAT LED, red color; active-high, forward current 12 mA
41	GPIO4_LED	O	0...+3.3V	REC LED, green color; active-high, forward current 12 mA
42	GND		GND	Ground
43	GPIO5	I/O	0...+3.3V	Input: USB host/device mode Output: REC LED, red color; active-high, forward current 4 mA
44	USB_D-	I/O	TTL	USB data minus
45	PORESET*	I/O	LVTTTL	Reset board; active-low
46	USB_D+	I/O	TTL	USB data plus
47	UART4_RTS	O	LVTTTL	UART 4, Request to Send
48	USB_PWR	I/O	+5V	+5V@500mA output in host mode +5V input in device mode
49	UART4_RXD	I	LVTTTL	Serial data input to UART 4
50	EVENT0	I	LVTTTL	Event marker input
51	UART4_TXD	O	LVTTTL	Serial data output from UART 3
52	GND		GND	Ground
53	UART4_CTS	I	LVTTTL	UART 4, Clear to Send
54	SDAT0B	I/O	3.3V	SD read/write data line 0
55	UART5_TXD	O	LVTTTL	Serial data output from UART 5
56	GND		GND	Ground
57	UART5_RXD	I	LVTTTL	Serial data input to UART 5
58	SDAT1B	I/O	3.3V	SD read/write data line 1

**Table 19. Interface Connector J201**

Pin No.	Signal Name	I/O	Signal Level	Description
59	UART6_TXD	O	LVTTL	Serial data output from UART 6
60	GND		GND	Ground
61	UART6_RXD	I	LVTTL	Serial data input to UART 6
62	SDAT2	I/O	3.3V	SD read/write data line 2
63	SDWP	I	3.3V	SD write protect; internally pulled-up to 1.8V with a 100 KOhm resistor
64	GND		GND	Ground
65	SDPWR	O	3.3V	SD power +3.3V
66	SDAT3	I/O	3.3V	SD read/write data line 3
67	SDCD	I	3.3V	SD card detect; internally pulled-up to 1.8V with a 100 KOhm resistor
68	GND		GND	Ground
69	SDCMDDB	I/O	3.3V	SD command/response
70	SDCLKB	O	3.3V	SD clock
71	CAN_TX/UART5_RTS	O	LVTTL	CAN Transmit/UART 5, Request to Send
72	CAN_RX/UART5_CTS	I	LVTTL	CAN Receive/UART 5, Clear to Send
73	GND		GND	Ground
74	GND		GND	Ground
75				Factory reserved. Leave this pin unconnected.
76				Factory reserved. Leave this pin unconnected.
77				Factory reserved. Leave this pin unconnected.
78				Factory reserved. Leave this pin unconnected.
79				Factory reserved. Leave this pin unconnected.
80				Factory reserved. Leave this pin unconnected.

## Test Pads and Points



For greater testability during the evaluation and development process, the B125EVB board has the following testing facilities:

- two test pads, J207 and J208, that duplicate some of the pins on the interface connector J201. You may use an oscilloscope, multi-meter, or any other measuring device to connect to the pins of test pads for signal inspection.

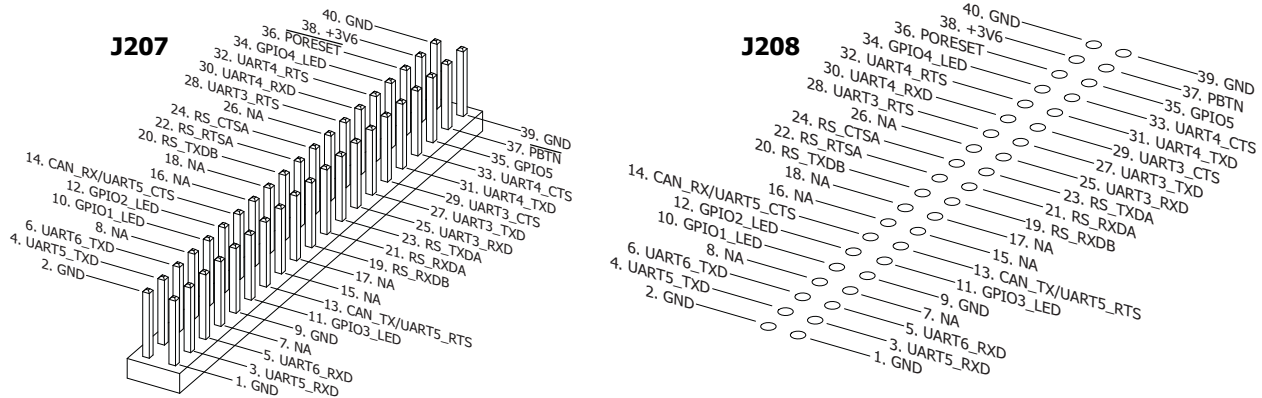
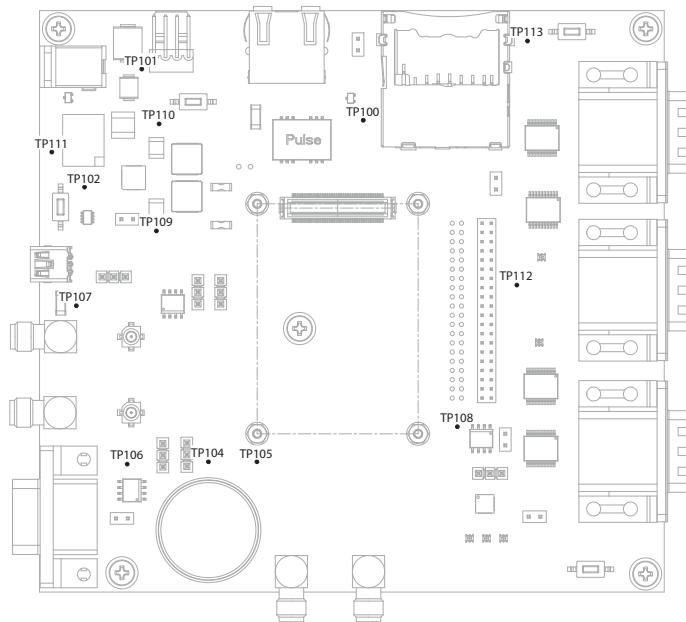

Figure 17: Test Pads

- 13 test points (Figure 18 on page 37)
  - nine ground test points, TP100, TP106...TP113, that are connected to a ground plane. These test points make it easier to connect a measuring device to ground when you are probing B125EVB components.
  - four voltage test points, TP101, TP102, TP104, and TP105, that are used to verify the voltages across the B125EVB.
    - TP101 measures the input voltage of an external power supply.
    - TP102 measures the voltage of the 3V3 power rail, which is used to power various components of the B125EVB.
    - TP104 connects with the positive terminal of the backup battery and with one of the terminals of a 1 kOhm resistor R139; TP105 connects with the other terminal of a 1 kOhm resistor R139 and with the VBAT rail, which extends directly to the VBAT pin no. 22 on the J201 connector. You can use these two test points to measure the current drawn by the connected B125 board when an external power supply has been discharged or removed.



**Figure 18: Test Points**

## UART Interfaces



The B125EV board accommodates six UART interfaces that are used for communication between the B125 board and external devices at the data rate of up to 460.8 Kbit/s. These interfaces are converted from TTL inputs to RS-232 outputs and are then connected to 9-pin D-shell male connectors:

- J200:1 (port A) and J200:2 (port B) use an RS-232 transceiver ISL4245EIRZ from Intersil, which is installed on the B125 board.
- J206:1 (port C), J206:2 (port D), J209:1 (port E), and J209:2 (port F) use RS-232 transceivers MAX3225EEAP+ from Maxim Integrated, which are installed on the B125EV board.

Serial ports A, C, D, and E provide flow control, while serial ports B and F have only three essential lines TX, RX, and GND.

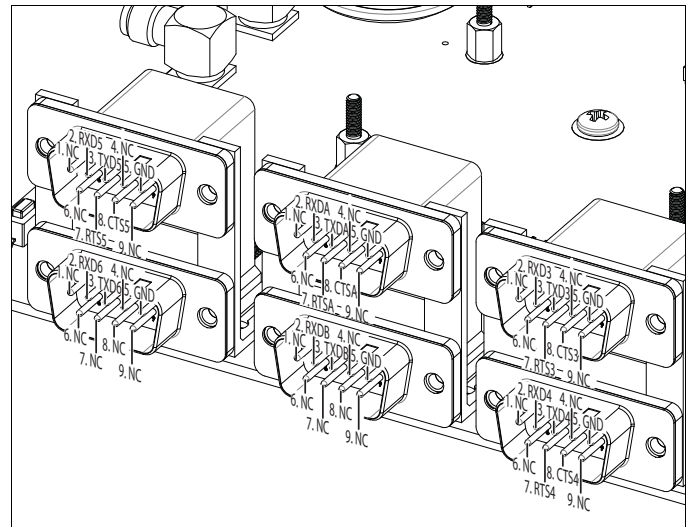

**Figure 19: UART Interfaces**

For communication with a computer, a 9-pin female to 9-pin female null modem cable is required. This cable (p/n 14-008086-01) is included to the [development kit](#).



Serial ports A, B, and C are the only ports you can use for control and data transfer. Ports D, E, and F are used for internal communications.

### Further Reading:

General design guidelines in [“General Guidelines”](#) on page 23.



## USB



The B125EVb board integrates a single USB type mini-AB connector J220, which extends to the J201 connector. The USB connection serves two purposes:

1. In host mode, you can connect a [USB flash memory device](#) to the B125 board for TPS data recording, storage, and retrieval.



A USB host functionality is currently disabled. It will be enabled through a future firmware update.

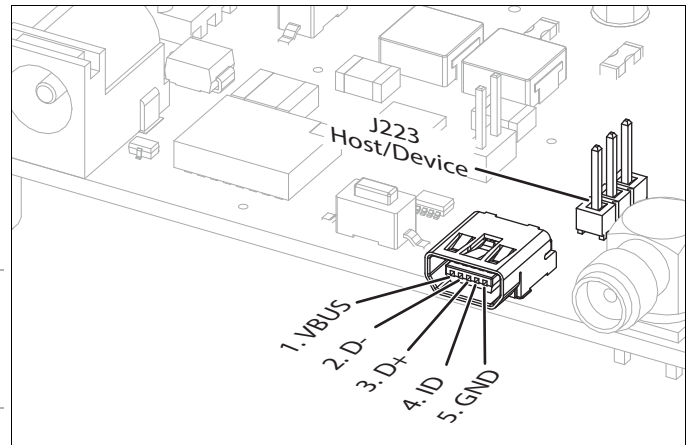

**Figure 20: USB Interface; J223 Jumper**

2. In device mode, you can use the USB interface of the B125 to connect to a computer for configuration and data exchange. Before establishing a USB connection in device mode, make sure that the TPS USB driver is installed on the host (i.e., computer).

Use the jumper [J223](#) to switch between host and device modes.



Before you move any jumpers, power off the B125EVb and B125.

### Further Reading:

- A description of the USB functionality on the B125 board in ["USB" on page 12](#).
- A description of the file system in ["File System" on page 20](#).
- General design guidelines in ["General Guidelines" on page 23](#).
- Design guidelines about USB host/device in ["USB" on page 23](#).
- A description of the jumper J223 in ["Jumpers" on page 32](#).
- GRIL commands used to configure the B125 to record, store, and transfer TPS data files to and from the USB flash memory devices in the [GRIL Reference Manual](#).

## Ethernet



The Ethernet port provides a TCP/IP network connectivity and is designed as an RJ45 connector with a discrete magnetics isolation module HX0068ANL from Pulse Electronics. The connector has two status LEDs:

- The Link LED indicates that the B125 has a valid Ethernet connection with an active device on the network. This LED should light steadily green.
- The Activity LED is off and is retained for future updates.

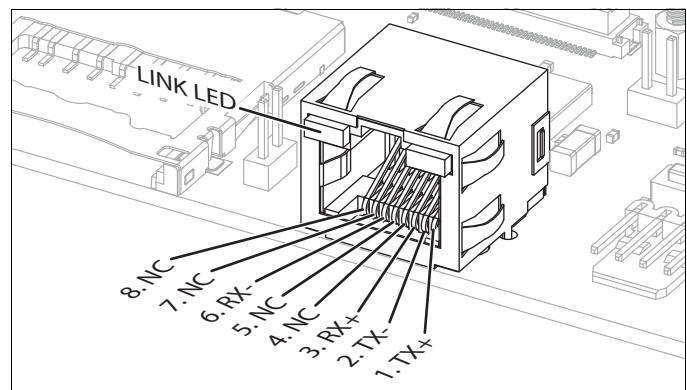

**Figure 21: Ethernet Interface**



A remote firmware update in the B125 requires support of Ethernet and SD card. The B125 uses Ethernet to copy the firmware file to the SD card using Topcon Data Transfer Protocol or FTP. The firmware update procedure is described in the [B125 Maintenance Guide](#).

**Further Reading:**

- A description of the Ethernet functionality on the B125 board in ["Ethernet" on page 14](#).
- A description of supported network services and protocols in ["Network Services and Protocols" on page 19](#).
- General design guidelines in ["General Guidelines" on page 23](#) and design guidelines about Ethernet in ["Ethernet" on page 23](#).
- GRIL commands to configure various network features and protocols in the [GRIL Reference Manual](#).

**CAN**

The B125EV board incorporates an independent CAN port that conforms to the CAN specification 2.0 A/B and NMEA 2000 standard. This port is a 9-pin D-shell female connector J202 with a discrete CAN transceiver SN65HVD230QD from Texas Instruments. To activate the CAN port, place the jumpers over header pin nos. 2 and 3 of J210 and J211 as shown in ["Jumpers" on page 32](#). Also, the CAN port has a termination header, J203, where you can set a jumper. By placing the jumper over the pins, you apply a load of 120 Ohm across the CAN data lines. If you do not need a CAN termination resistor, remove the jumper.

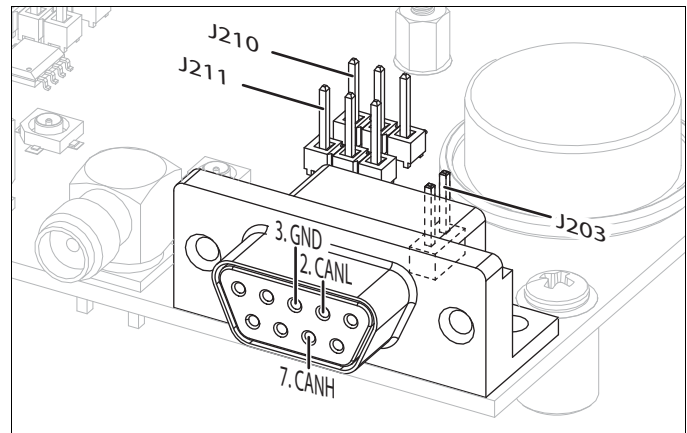
**Figure 22: CAN Interface****Further Reading:**

- A description of the CAN functionality on the B125 board in ["CAN" on page 13](#).
- General design guidelines in ["General Guidelines" on page 23](#).
- A description of CAN-related jumpers in ["Jumpers" on page 32](#).
- How to configure various CAN settings, including the baud rate and node addresses, output of NMEA 2000 messages, etc., in the [GRIL Reference Manual](#).

**SD Card**

The B125EV board provides one SD card slot J221 for connection to an [SD/SDIO interface](#) on the B125 board. You can use this slot to connect an SD/SDHC card for TPS data recording and storage.



The firmware update in the B125 requires support of the SD card. The B125 uses the SD card to store the firmware file. The firmware update procedure is described in the [B125 Maintenance Guide](#).

**Further Reading:**

- Storage medium details and design guidelines in ["SD/SDIO" on page 15](#) and ["SD/SDIO" on page 24](#).
- A description of the file system in ["File System" on page 20](#).
- General design guidelines in ["General Guidelines" on page 23](#).
- SD cards approved for use in ["Approved SD Cards" on page 24](#).
- GRIL commands to record, store, and transfer TPS data files in the [GRIL Reference Manual](#).

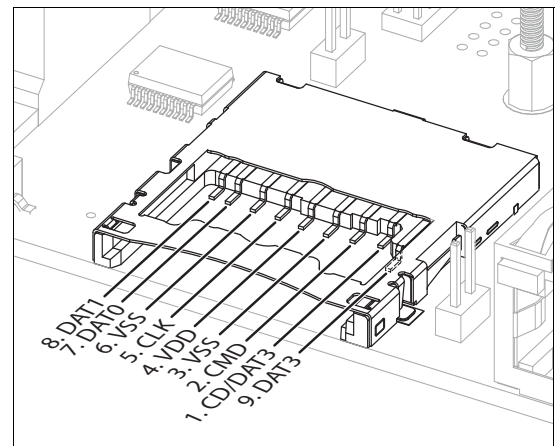
**Figure 23: SD Card**

## Backup battery



The B125EVB board contains a backup battery (B100) shown on [Figure 24](#). The backup battery preserves the contents of the NVRAM and runs the real-time clock when the connected B125 is turned off. The B125EVB uses the Tadiran Batteries' lithium battery TL-2450. This battery is rated at about 8 years of operation at typical consumption and ambient temperature of 25° C.

### Further Reading:

Details about the backup functionality in ["Backup Power Rail"](#) on page 7.

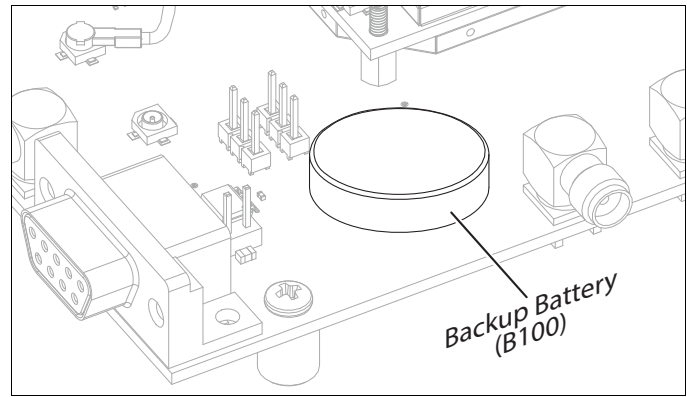

**Figure 24: Backup Battery**



## 1PPS

The B123EVB features a single 1PPS output. It extends from pin no. 29 on the J201 connector to a 50-Ohm SMA R/A Jack, J219.

### Further Reading:

- A description of the 1PPS signal in ["1PPS"](#) on page 14 and ["Board Specifications"](#) on page 41.
- General design guidelines in ["General Guidelines"](#) on page 23.
- GRIL commands to configure the 1PPS functionality in the [GRIL Reference Manual](#).

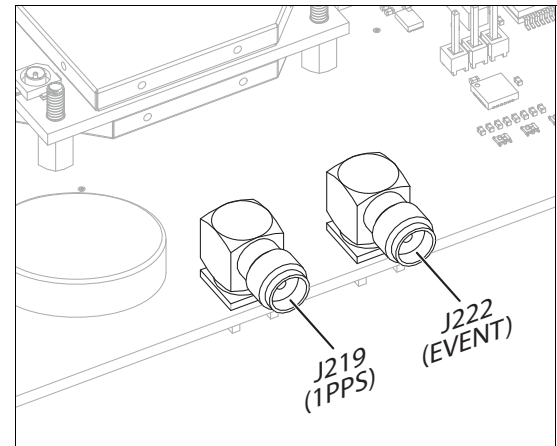

**Figure 25: 1PPS and Event Marker**



## Event Marker

The B123EVB features a single event marker input. It extends from pin no. 50 on the J201 connector to a 50-Ohm SMA R/A Jack, J222 ([Figure 25](#)).

### Further Reading:

- A description of the event marker signal in ["Event Marker"](#) on page 15 and ["Board Specifications"](#) on page 41.
- General design guidelines in ["General Guidelines"](#) on page 23.
- GRIL commands to configure the event marker functionality in the [GRIL Reference Manual](#).

## Board Specifications

Table 20 provides specifications for the B125 board, including hardware and firmware components.

**Table 20. B125 Board Specifications**

<b>Physical</b>	
Dimensions	L: 55 mm x W: 40 mm x H: 10 mm (2.17 in x W: 1.57 in x H: 0.39 in)
Weight	0.02 kg (0.04 lbs)
Mounting	Four holes to install M2 screws
Connector	80-pin receptacle of DF17 series, Hirose DF17(3.0)-80DS-0.5V(57)
<b>Environment</b>	
Operating temperature	-40° C to +75° C
Storage temperature	-40° C to +85° C
Humidity	95%, non-condensing
Vibration	4g Sine Vibe (SAEJ1211) 7.7g Random Vibe (MIL-STD 810F)
Acceleration	20g
Jerk	3g/sec
Shock	Operational IEC68-2-27,11ms,40g Survival IEC68-2-27,11ms,75g
<b>Power</b>	
Input voltage	+3.4 to +5.5 Vdc
Voltage ripple	150 mV p-p max
Consumption <sup>a</sup>	≤ 2 W typical; 3 W max
<b>Antenna</b>	
Number of connectors	2
Connector type	Hirose H.FL Straight Through Hole
Nominal impedance	50 Ohm
RF input frequencies	1557 – 1614 MHz (GPS/GLONASS L1, Galileo E1, BeiDou B1, QZSS L1) 1203 – 1258 MHz (GPS/GLONASS L2, Beidou B2, QZSS L2) 1162 – 1222 MHz (GPS L5, GLONASS L3, Galileo E5, BeiDou B2, QZSS L5) 1525 – 1560 MHz (L1 band)
LNA power	+3.4 to +5.5 Vdc @ 0 - 120 mA (J100) +4.8 to +5.16 Vdc @ 0 - 120 mA (J101)
Overcurrent values	min: 102mA, typ: 115 mA, max: 140 mA

Table 20. B125 Board Specifications (Continued)

Communication Interfaces	
RS-232 interface Number of interfaces Electrical and mechanical Connection method Transmission mode Baud rate Data length Stop bit Parity Flow control	2 Conforms to EIA RS-232 Point-to-point Full-duplex 4800, 9600, 19200, 38400, 57600, 115200 (default), 230400, and 460800 7 or 8 (default) bits 1 (default) or 2 bits No parity (default), even, or odd RTS/CTS (hardware handshaking) on serial port A
LVTTTL interface Number of interfaces Electrical specifications Connection method Transmission mode Baud rate Data length Stop bit Parity Flow control	4 LVTTTL Point-to-point Full-duplex 4800, 9600, 19200, 38400, 57600, 115200 (default), 230400, 460800 7 or 8 (default) bits 1 (default) or 2 bits No parity (default), even, or odd RTS/CTS (hardware handshaking) on serial ports C, D, and E
USB interface Number of interfaces Architecture Electrical and mechanical Data rate	1 USB host <sup>b</sup> /device Conforms to USB Rev. 2.0 480 Mbps max
Ethernet Interface Number of interfaces Electrical and mechanical Transmission method Data rate Communication protocol Supported services LED indicator	1 Conforms to IEEE 802.3 Ethernet (10BASE-TX/100BASE-T) 10 Mbps/100 Mbps TCP/IP TCP Server/Client, FTP Server/Client, DNS server, Ntrip Server/Client One LED – Activity status
CAN interface Number of interfaces Electrical and mechanical Format of output data	1 (w/o transceivers) Conforms to CAN 2.0 A/B NMEA 2000
I/O Signals	
1PPS Number of outputs Polarity Signal level Pulse width Rise/Fall time Synchronization edge Resolution Period Offset Reference time	1 Positive pulse ≥ 2 V, LVTTTL into 50 Ohm load 3.3 msec (normal pulse); 5.3 msec (marked pulse) ≤ 3 nsec Rising/Falling (user selectable) 5 nsec 10 to 1000000000 msec (user selectable) -500000000 to 500000000 msec; -500000 to 500000 nsec (user selectable) GPS, GLONASS, UTC (USNO), UTC (SU) (user selectable)

**Table 20. B125 Board Specifications (Continued)**

Event Marker	
Number of inputs	1
Polarity	Positive pulse
Input low voltage levels	from 0.0 V to +0.8 V
Input high voltage levels	from +2.0 V to +3.3 V
Internal pull-up resistor value	10 kOhm to +3.3 V
Pulse width	≥ 100 nsec
Synchronization edge	Rising/Falling (user selectable)
Resolution	5 nsec
Reference time	GPS, GLONASS, UTC (USNO), UTC (SU) (user selectable)
LED	One on-board LED – STAT satellite and receiver status Five GPIO signals for external STAT and REC LEDs
<b>Tracking Specifications</b>	
Standard Channels	224 universal channels 2 dedicated channels for L band
Tracked Signals	GPS: L1C/A, L1P, L1C, L2P, L2C, L5 GLONASS: L1C/A, L1P, L2C/A, L2P, L3 Galileo: E1, E5AltBOC, E5a, E5b Beidou: B1, B2 QZSS: L1C/A, L1C, L1-SAIF, L2C, L5 SBAS:WAAS L1, EGNOS, MSAS, GAGAN L-Band PPP
Time to First Fix (50%)	Hot (almanac & recent ephemeris and approx. position) <10 sec Warm (almanac, approx. position & time, no recent ephemeris) <35 sec Cold (no almanac or ephemeris and no approx. position or time) <60 sec
Reacquisition	<1 sec
<b>Tracking Functions</b>	
Multipath reduction	C/A code phase and carrier phase
PLL/DLL/QLL settings	User-configurable
Pseudorange smoothing	Adjustable
Cinderella days	Cinderella days is an option that turns a single frequency board into a dual-frequency, GPS+GLONASS board for 24 hours every other Tuesday at GPS midnight. Refer to Topcon's website at <a href="http://www.topconpositioning.com">www.topconpositioning.com</a> for more information and specific Cinderella day dates.
<b>Data Features</b>	
Formats	Proprietary (TPS) data format NMEA 0183 versions 2.1, 2.2, 2.3 and 3.0, 3.01 NMEA 2000 over CAN RTCM SC104 versions 2.1, 2.2, 2.3, 3.0 and 3.1 CMR/CMR+ (public version) <sup>c</sup> BINEX

Table 20. B125 Board Specifications (Continued)

Supported Messages TPS BINEX NMEA 0183 NMEA 2000 RTCM 2.x RTCM 3.x  CMR/CMR+	Binary and ASCII messages; see the <a href="#">GRIL Reference Manual</a> for a list. 00_00, 01_01, 7E_00, 7D_00, 7F_02, 7F_03, 7F_04 GGA, GLL, GNS, GRS, GSA, GST, GSV, HDT, RMC, VTG, ZDA, ROT, GMP, ATT, VHD 129029, 129025 1, 3, 6, 9, 15, 16, 18...24, 31, 32, 34, 36, 59t 1003...1008, 1011, 1012, 1014...1017, 1019...1028, 1030...1033, 4087G, 4087N, 4091i, 4091t, 4091h, 1071...1077, 1081...1087, 1091...1097, 1111...1117, 1121...1127, 1230 0, 1, 2, var (3), 5, +
Update and output rates Raw measurements Position (Standalone, DGPS, RTK)	up to 100 Hz up to 50 Hz
<b>Memory</b>	
Media type	industrial SD card (removable), USB drive (removable)
Capacity	up to 32 GB
File system	FAT32
Number of files	up to 3000
Logging size	3.5 MB per hour (18 SVs, 1 sec, L1/L2, default message set)
Logging interval	0.05 to 86400 seconds, depending on purchased options
<b>Accuracy<sup>d</sup> (rms)</b>	
Standalone	Horizontal 1.2 m Vertical 1.8 m
RTCM based DGPS	Horizontal 0.3 m Vertical 0.5 m
SBAS	Horizontal 0.8 m Vertical 1.2 m
TopNET Global -D (PPP)	Horizontal < 0.1 m (95%) Vertical < 0.2 m (95%) Pass-to-pass (horizontal) < 5 cm (95%) & < 15 minutes
Static/Fast Static	Horizontal 3 mm + 0.5ppm (x baseline length) Vertical 5 mm + 0.8ppm (x baseline length)
RTK Static	Horizontal 3 mm + 0.5ppm (x baseline length) Vertical 5 mm + 0.8ppm (x baseline length)
RTK Kinematic/Stop&Go/Network	Horizontal 5 mm + 0.5ppm (x baseline length) Vertical 10 mm + 0.8ppm (x baseline length)
Heading (HD2 mode)	0.2°/D, where D is the inter-antenna distance in meters
Inclination (HD2 mode)	0.3°/D, where D is the inter-antenna distance in meters
Velocity	0.02 m/sec
Time	30 nsec

a. Without a connected GNSS antenna and USB host.

b. A USB host functionality is currently disabled. It will be enabled through a future firmware update.

c. CMR/CMR+ is a third-party proprietary format. Use of this format is not recommended and performance cannot be guaranteed. Use of industry standard RTCM 3.x is always recommended for optimal performance.

- d. These specifications will vary depending on the number of satellites used, obstructions, satellite geometry (PDOP), occupation time, multipath effects, and atmospheric conditions. Performance may be degraded in conditions with high ionospheric activity, extreme multipath, or under dense foliage. For maximum system accuracy, always follow best practices for GNSS data collections.

## Connector Specifications

The B125 board has a single interface connector for power and data management, and two GNSS antenna connectors.

### Interface Connector

The interface connector is a 80-pin receptacle of Hirose DF17 series, part number DF17(3.0)-80DS-0.5V(57). This connector mates with a Hirose header DF17(2.0)-80DP-0.5V(57).

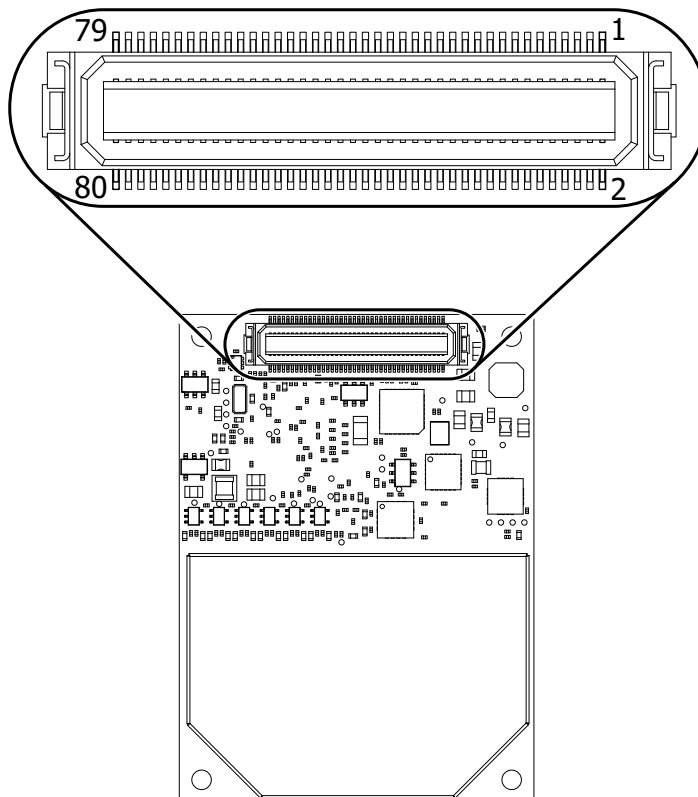

**Figure 26: Interface Connector**

Table 21 gives pin assignments of the interface connector J500.

**Table 21. Interface Connector**

Pin No.	Signal Name	I/O	Signal Level	Description
1	+5V	I	+5V	+5V, Power supply to USB host and GNSS antenna at J101
2	PWR_IN	I	+3.4...5.5 V	Primary power supply input
3	GND		GND	Ground
4	PWR_IN	I	+3.4...5.5 V	Primary power supply input
5	GND		GND	Ground
6	PWR_IN	I	+3.4...5.5 V	Primary power supply input
7	TXN	O		Ethernet TX negative output



Table 21. Interface Connector

Pin No.	Signal Name	I/O	Signal Level	Description
8	3V3_LAN	O	0...+3.3V	Ethernet power
9	TXP	O	0...+3.3V	Ethernet TX positive output
10	ETH_LED1	O	0...+3.3V	Ethernet LED activity indicator, active-low
11	GND		GND	Ground
12				Factory reserved. Leave this pin unconnected.
13	RXN	I		Ethernet RX negative input
14				Factory reserved. Leave this pin unconnected.
15	RXP	I		Ethernet RX positive input
16				Factory reserved. Leave this pin unconnected.
17	GND		GND	Ground
18				Factory reserved. Leave this pin unconnected.
19	FN_BTN*	I	0...+3.3V	Function button, active-low
20	PBTN*	I	0...+3.3V	Power button, active-low
21				Factory reserved. Leave this pin unconnected.
22	VBAT	I	0...+3.6V	Backup power supply
23	UART3_TXD	O	LVTTTL	Serial data output from UART 3
24	UART3_RXD	I	LVTTTL	Serial data input to UART 3
25	UART3_RTS	O	LVTTTL	UART 3, Request to Send
26	UART3_CTS	I	LVTTTL	UART 3, Clear to Send
27	GND		GND	Ground
28				Factory reserved. Leave this pin unconnected.
29	1PPSA	O	LVTTTL	1PPS output
30				Factory reserved. Leave this pin unconnected.
31	RS_TXDB	O	RS-232	Serial data output from port B
32	RS_RXDB	I	RS-232	Serial data input to port B
33	GPIO1_LED	O	0...+3.3V	STAT LED, blue color; active-high, forward current 12 mA
34	GND		GND	Ground
35	RS_RTSA	O	RS-232	Port A, Request to Send
36	RS_CTSA	I	RS-232	Port A, Clear to Send
37	RS_TXDA	O	RS-232	Serial data output from port A
38	RS_RXDA	I	RS-232	Serial data input to port A
39	GPIO2_LED	O	0...+3.3V	STAT LED, green color; active-high, forward current 12 mA
40	GPIO3_LED	O	0...+3.3V	STAT LED, red color; active-high, forward current 12 mA

Table 21. Interface Connector

Pin No.	Signal Name	I/O	Signal Level	Description
41	GPIO4_LED	O	0...+3.3V	REC LED, green color; active-high, forward current 12 mA
42	GND		GND	Ground
43	GPIO5	I/O	0...+3.3V	Input: USB host/device mode Output: REC LED, red color; active-high, forward current 4 mA
44	USB_D-	I/O	TTL	USB data minus
45	PORESET*	I/O	LVTTTL	Reset board; active-low
46	USB_D+	I/O	TTL	USB data plus
47	UART4_RTS	O	LVTTTL	UART 4, Request to Send
48	USB_PWR	I/O	+5V	+5V@500mA output in host mode +5V input in device mode
49	UART4_RXD	I	LVTTTL	Serial data input to UART 4
50	EVENT0	I	LVTTTL	Event marker input
51	UART4_TXD	O	LVTTTL	Serial data output from UART 3
52	GND		GND	Ground
53	UART4_CTS	I	LVTTTL	UART 4, Clear to Send
54	SDAT0B	I/O	3.3V	SD read/write data line 0
55	UART5_TXD	O	LVTTTL	Serial data output from UART 5
56	GND		GND	Ground
57	UART5_RXD	I	LVTTTL	Serial data input to UART 5
58	SDAT1B	I/O	3.3V	SD read/write data line 1
59	UART6_TXD	O	LVTTTL	Serial data output from UART 6
60	GND		GND	Ground
61	UART6_RXD	I	LVTTTL	Serial data input to UART 6
62	SDAT2	I/O	3.3V	SD read/write data line 2
63	SDWP	I	3.3V	SD write protect; internally pulled-up to 1.8V with a 100 KOhm resistor
64	GND		GND	Ground
65	SDPWR	O	3.3V	SD power +3.3V
66	SDAT3	I/O	3.3V	SD read/write data line 3
67	SDCD	I	3.3V	SD card detect; internally pulled-up to 1.8V with a 100 KOhm resistor
68	GND		GND	Ground
69	SDCMDB	I/O	3.3V	SD command/response
70	SDCLKB	O	3.3V	SD clock
71	CAN_TX/UART5_RTS	O	LVTTTL	CAN Transmit/UART 5, Request to Send
72	CAN_RX/UART5_CTS	I	LVTTTL	CAN Receive/UART 5, Clear to Send

**Table 21. Interface Connector**

Pin No.	Signal Name	I/O	Signal Level	Description
73	GND		GND	Ground
74	GND		GND	Ground
75				Factory reserved. Leave this pin unconnected.
76				Factory reserved. Leave this pin unconnected.
77				Factory reserved. Leave this pin unconnected.
78				Factory reserved. Leave this pin unconnected.
79				Factory reserved. Leave this pin unconnected.
80				Factory reserved. Leave this pin unconnected.

## GNSS Antenna Connectors

Two GNSS antenna connectors are Hirose H.FL-R-SMT. Table 22 gives specifications of GNSS antenna connectors.

**Table 22. GNSS Antenna Connector Specifications**

Pin No.	Signal	Direction	Description
Central	ANT_IO	I/O	Input: RF signals from antenna J100 Output: +3.4 - +5.5 Vdc @ 0 - 120 mA depends on PWR_IN J101 Output: +5.0 Vdc @ 0 - 120 mA (J101) powered through pin no. 1

# Mechanical and Schematic Drawings

## B125 Dimensions

Figure 27 shows overall dimensions of the B125 board with the relative dimensions of the connectors and mounting holes. All values are given in millimeters.

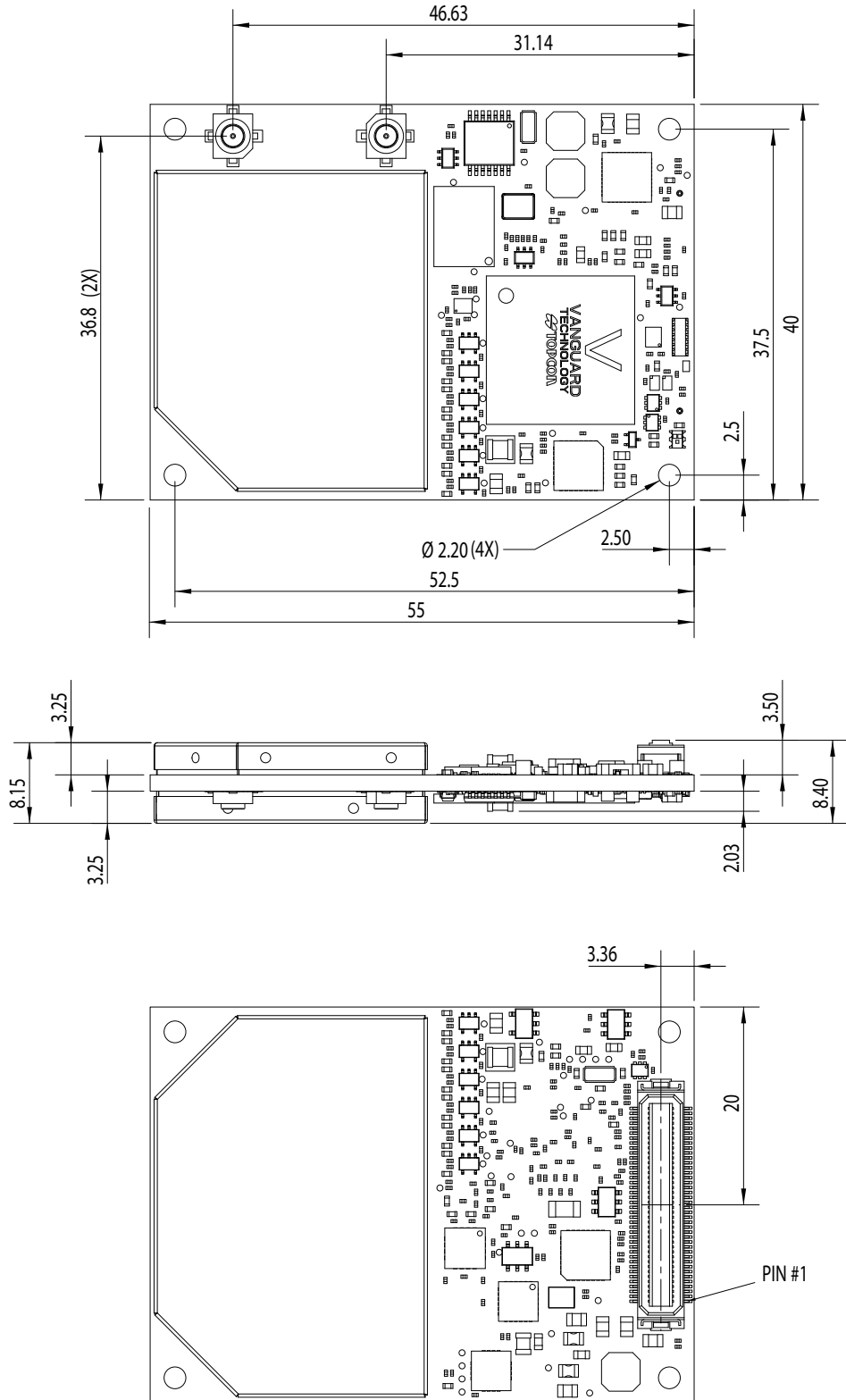

**Figure 27: B125 Mechanical Drawing**

# B125EVB Schematics

The following schematics show circuit components of the B125EVB and how they are electrically connected.

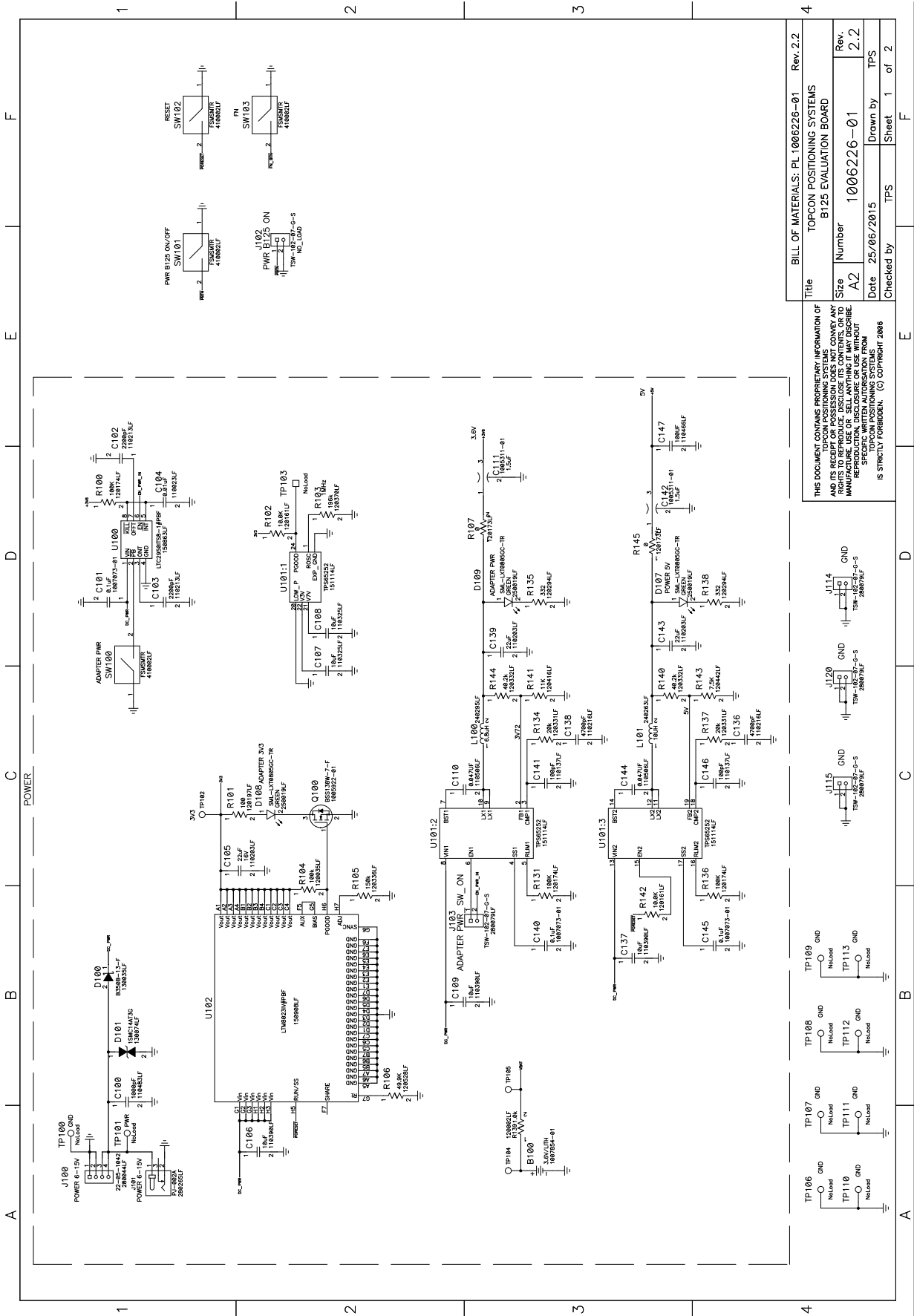

Title		Rev. 2.2	
TOPCON POSITIONING SYSTEMS		B125 EVALUATION BOARD	
Size	Number	Rev.	
AZ	1006226-01	2.2	
Date	25/05/2015	Drawn by	TPS
Checked by	TPS	Sheet	1 of 2

THIS DOCUMENT CONTAINS PROPRIETARY INFORMATION OF TOPCON POSITIONING SYSTEMS. NO PARTS MAY BE REPRODUCED OR TRANSMITTED IN ANY FORM OR BY ANY MEANS, ELECTRONIC OR MECHANICAL, INCLUDING PHOTOCOPYING, RECORDING, OR BY ANY INFORMATION STORAGE AND RETRIEVAL SYSTEM, WITHOUT PERMISSION IN WRITING FROM TOPCON POSITIONING SYSTEMS. (C) COPYRIGHT 2006

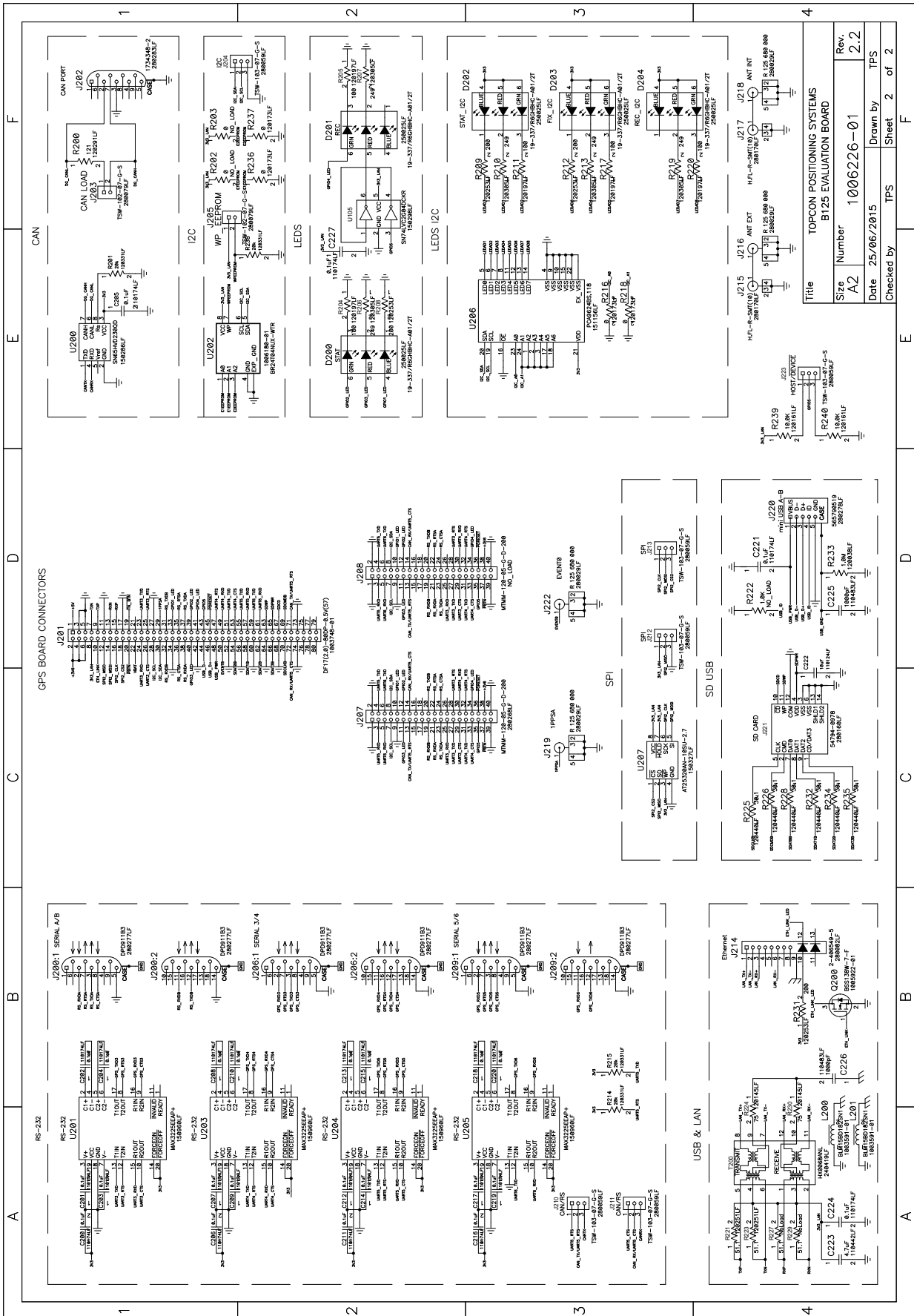

Title	TOPCON POSITIONING SYSTEMS B125 EVALUATION BOARD
Size	AZ
Number	1006226-01
Rev.	2.2

Date 25/06/2015  
Checked by TPS  
Drawn by TPS  
Sheet 2 of 2



[www.topconpositioning.com](http://www.topconpositioning.com)